

# TUBE•LINE™

Tubeline Manufacturing Limited  
6455 Reid Woods Drive RR #4  
Elmira, Ontario, Canada N3B 2Z3

Email: [sales@tubeline.ca](mailto:sales@tubeline.ca)

Fax: 519.669.5808

Tel: 519.669.9488

Toll-free (North America): 1.888.856.6613

[www.tubeline.ca](http://www.tubeline.ca)

# Operator's Manual

Keep this manual with the machine at all times.



Bale Shredder

# Boss IV

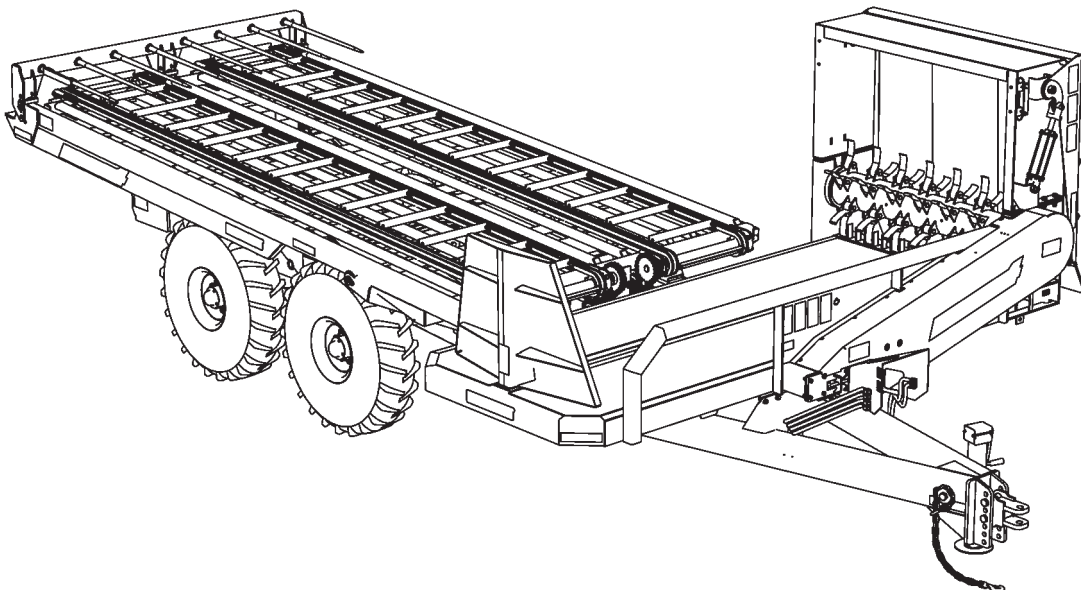

# Operator's Manual

Thank you for choosing the Tubeline Boss IV Bale Processor. Our hope is that it will give you many years of productive service. This machine is designed to carry and spread large square bales.

## Parts Section Usage

The parts section of this manual is used to order replacement parts by means of part breakdowns and their corresponding part lists. Each page contains a different range of integrated parts. Each illustration visually represents machine components. The part lists contain information needed to order replacement parts. Part lists include the following columns:

**ITEM** - Number matching parts breakdown balloons.

**QTY** - Quantity of components included in this breakdown, not entire machine.

**PART NUMBER** - The number to be used when placing an order.

**DESCRIPTION** - Term used to confirm its matching part number.

**NOTE** - Column may be added to part lists when a serial break or additional information is required.

Remember to always have your machine model and serial number on hand when ordering parts.

## Part Orders

Part orders are taken by your local Tubeline dealer and fulfilled through a regional distributor. For quick service please record your dealer name and contact information in the *Serial Number* section.

## Manuals

Manuals are printed and shipped with machines as they leave the manufacturer. Your machine may include parts or features not yet included in the initially shipped manual. The latest manual version can be found at [www.tubeline.ca/support.php](http://www.tubeline.ca/support.php). Tubeline reserves the right to update and change manuals as seen fit. Dealers are informed of any pressing changes/ modifications. They can help you with any questions regarding replacement parts.

## Serial Number

The implement serial number is located above the PTO driveshaft. (See *to right*) This number helps us to track changes and improvements and must be mentioned when ordering parts or requesting service. For your convenience, a space has been provided inside the front cover of this manual to record the serial number, model number, purchase date, and dealer name.

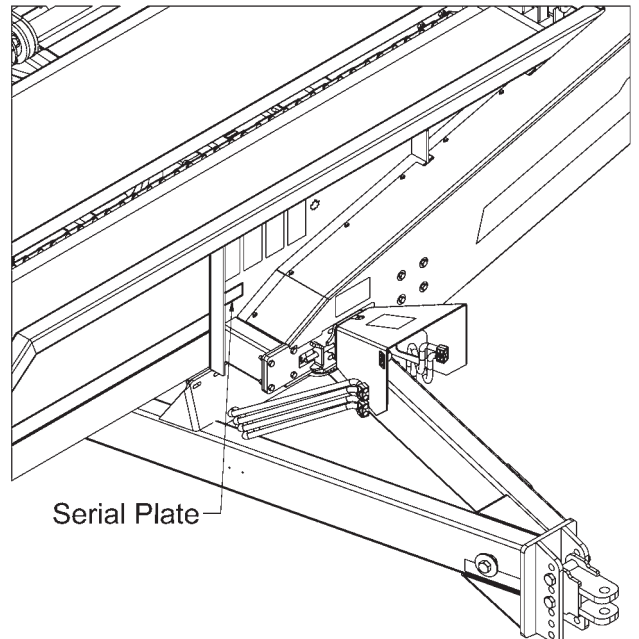

Model No: \_\_\_\_\_ Boss IV \_\_\_\_\_

Serial No: \_\_\_\_\_

Date Purchased: \_\_\_\_\_

Dealer Name: \_\_\_\_\_

Dealer Contact: \_\_\_\_\_

## Warranty and Limitation of Liability

All Equipment is sold subject to mutual agreement that it is warranted by Tube-Line Manufacturing Ltd (hereinafter the company) to be free from defects in material and workmanship. The company's liability shall be limited exclusively to the original owner to replace or repair without charge, at its factory or elsewhere, at its discretion, any defects in material or workmanship which become apparent in the first year from the date on which the equipment was purchased. Components supplied by third parties and not manufactured by the company will carry such warranty as extended by such parties, such as but not limited to, tires, batteries, electrical components, hydraulics and engines.

The buyer by the acceptance of the equipment will assume all liability for any damages which may result from accident, abuse or misuse by his employees or others. Any equipment that has been altered or modified without prior written authorization by the company will render the warranty null and void.

No employee or representative of the company is authorized to make changes to this warranty or grant additional warranty terms unless authorized in writing by management of the company.

The company shall not be liable for special, indirect or consequential damages of any kind including but not limited to, loss of revenue, rental replacement costs or other losses.

Normal wear and tear from normal use of the equipment is not warranted. The end user is expected to maintain and service the equipment in accordance with accepted practices. Failure to do so will void the terms of this warranty.

Warranty coverage is null and void unless Warranty Registration form has been completely filled in and is on file at Tube-Line Manufacturing Ltd.

**NOTE:** Newest manual version can be found at [www.tubeline.ca/support.php](http://www.tubeline.ca/support.php)

# Table of Contents

<b>Operator's Manual</b>	<b>I</b>
Parts Section Usage	I
Part Orders	I
Manuals	I
Serial Number	I
Warranty and Limitation of Liability	II
<b>Section 1: Safety</b>	<b>1-1</b>
Learn Machine Safety	1-1
Safety Signal Words / Safety Messages	1-1
Transport Safety	1-1
Pre-Operation	1-1
Operational Safety	1-1
Parking Safety	1-2
Maintenance Safety	1-2
<b>Section 2: Adjustments &amp; Maintenance</b>	<b>2-1</b>
<b>Section 3: Operation</b>	<b>3-1</b>
Pre-Operation	3-1
Operating Procedure	3-1
<b>Section 4: Basic Parts</b>	<b>4-1</b>
Main Frame & Axles	4-2
Tongue - Up to SN 19B401	4-4
Tongue - SN 19B402 to Current	4-5
Deck Frame	4-6
Deck Drive	4-8
Lift Assist	4-10
Shredder - Up to SN 19B401	4-12
Shredder - SN 19B402 to Current	4-14
Shredder Chain Drive - Up to SN 19B401	4-16
Shredder Chain Drive - SN 19B402 to Current	4-18
Shredder Flail Drum - Up to SN 19B401	4-20
Shredder Flail Drum - SN 19B402 to Current	4-22
<b>Section 5: Hydraulics</b>	<b>5-1</b>
Hydraulic Layout - Up to SN 19B401	5-1
Hydraulic Layout - Wagon - SN 19B402 to Current	5-3
Hydraulic Layout - Shredder - SN 19B402 to Current	5-5
<b>Section 6: Decals</b>	<b>6-1</b>
Decal Locations	6-1
Decal List	6-2
Clearance Markers	6-3
<b>Imperial Torque Value Chart</b>	<b>7-1</b>
<b>Metric Torque Value Chart</b>	<b>8-1</b>

# Section 1: Safety

## Learn Machine Safety

Carefully read this manual. Learn how to operate this machine and learn how to use the controls properly.

Do not let anyone operate this machine without proper instruction.

Unauthorized modifications to the machine may impair the function and/or safety and affect machine life.

### Safety Signal Words / Safety Messages



**CAUTION:** Indicates a potentially hazardous situation that may result in injury.

**WARNING:** Indicates a potentially hazardous situation that could result in serious injury or death.

**DANGER:** Indicates a hazardous situation that needs to be avoided. Operator needs to be aware of these dangers. High probability of serious injury or death.

**NOTE:** Indicates an informative non-safety related message.

### Transport Safely

- Disengage PTO.
- Do not tow loads that weigh more than twice the weight of the tractor.
- Reduce the tractor's speed when ground is rough.
- Always keep the tractor in gear when traveling down steep grades.
- To assure adequate braking performance and control, tow only with an agricultural tractor. Safe towing speed depends on the weight of the tractor and the towed load. Speed should never exceed 32kmh (20mph).

### Pre-Operation

- Become familiar with the controls.
- Check all hardware.
- Check all hydraulic hoses and connections.
- Check the condition of drive belts.
- Remove foreign objects from the machine.
- Inspect drive-line shield for free rotation.
- Be sure all guards are in place.

### Operational Safety

- Operate the machine from the tractor seat only.
- Avoid making sharp turns and turning on steep banked gullies. When working on inclines or slopes, travel uphill or downhill.

- Be sure to keep tractor transmission in gear when traveling down hill.
- Reduce tractor ground speed when turning or traveling on rough terrain. Avoid traveling over loose fill, rocks, ditches, or holes.
- Under no circumstances should a processor equipped with a 1000 rpm PTO processor be operated by a tractor with 540 rpm PTO.
- **DO NOT** allow riders on processor. **DO NOT** allow children to operate the tractor. **DO NOT** operate the machine near people.
- Drive slowly through doors and gates.

### **Parking Safety**

- Always park the processor on level ground and block the wheels when not in use.

### **Maintenance Safety**

- Always engage tractor parking brake or place transmission in “PARK”, lower fork to the ground, shut off the engine and remove key before servicing.
- Do not work under raised machine parts unless it is securely blocked or safety props are in position.
- Before disconnecting hydraulic hoses, relieve all hydraulic pressure.
- Understand service procedures before doing any work.
- Never lubricate or service machine while it is moving.
- Keep hands, feet, and clothing clear power-driven parts.
- Securely support any machine elements that must be raised for service work.
- Keep all parts in good condition and properly installed.
- Fix damage immediately.
- Replace worn or broken parts.
- Remove any buildup of grease, oil, or debris.

## Section 2: Adjustments & Maintenance



**CAUTION:** The flail tube in this machine is a fully balanced assembly. If for any reason the flails must be removed, they **MUST BE RETURNED** to the **SAME POSITION** they were taken from. If this is not done a balance problem will result causing machine vibration. Number flails and inserts and their positions before you do any work.

Before performing any maintenance or adjustments make sure machine is not running. If for any reason arc welding is to be done, always ground the cylinder to the frame of the machine prevent arcing in the bearings.

1. Check for loose and badly worn parts.
2. Conveyor chain should be adjusted to allow chain slack 1" (2.54 cm) to 1 1/2" (3.8 cm).
3. Follow the Lubrication Chart.
4. Inspect rotor and all rotating parts for twine or wire build-up.
5. Inspect and tighten Allen screws on bearings after the first 10 hours of operation.
6. Check air pressure in tires – 35lb.(15.9 kg).
7. Discharge deflector has adjustments to allow forage to be spread to any desired width.
8. Check for broken flails. Replace with new flails to keep the machine in balance.

# Section 3: Operation

## Pre-Operation

Make sure that bales are free from foreign objects. Foreign objects in bale may cause damage to the machine or cause injury or death to livestock, bystanders, or operator.

Make sure any bystanders are away from the machine and discharge before engaging PTO flying objects can cause serious injury or even death.

This machine is set-up to operate on a 1000 rpm PTO (540 rpm is optional). The machine's hydraulic system performs two functions:

One function tilts the deck for loading bales on top of the machine.

Slide the tines lightly on ground when loading bales with the deck up. Store bales on level ground so that the bales can be loaded with ease. Bales should be stored on a clean surface free from rocks and other foreign objects. Center the bales on the tines before loading on to the deck.

1. The second function powers the bale pusher by means of a hydraulic motor.

Desired speed of the pusher is controlled by a flow control valve located on the front of the machine. Decrease the speed of the pusher allows flail knives to chop forage finer, increasing the speed leaves forage coarser when the knives are in the upward position. Operating the tractor at maximum PTO rpm allows the machine to do a better job of chopping forage.



**CAUTION:** Twine build-up should be kept to a minimum to reduce fire hazard and keep the machine in balance. Check for cylinder wear and broken flails and flail bracket wear.

## Operating Procedure

Connect all six hoses (four on right side, two on left) to the tractor ports. Be sure to match up the paired hoses to the right ports to ensure proper operation. Also connect the PTO to the front shaft located at the front of the machine.

Prior to running the machine with bales, adjust the shredder's chute to the position likely to be used while operating.

**NOTE:** A good idea is to run the machine through the operating steps without bales to familiarize yourself with your new machine.

Use the tractors controls to raise the deck until it is upright. Gravity will bring the tines down 90 degrees to the deck.

Reverse into a stack of bales to a maximum of four bales high. Your bales should be no bigger than 4' x 4' x 9'.

Return the deck to its original position and drive to the area or row that you want to spread on, against etc.

**NOTE:** Make sure the spreaders chute is in the correct position for where you want your crop to go. Use the tractors controls to run the apron (deck) chain towards the tractor, this will move the bales.

Continue bringing bales forward until one is securely positioned on the shredder table.



Next, move the installed joystick to push the bale through the rotating flail drum to shred and throw the bale evenly over the desired location. *The flail drum is rotated by the PTO drive.*

Remember to run the bale shredder ram back to its original position to allow the next bale onto the table.

Finish spreading the bales in like manner and repeat for next bale stacks.

# Section 4: Basic Parts

# Main Frame & Axles

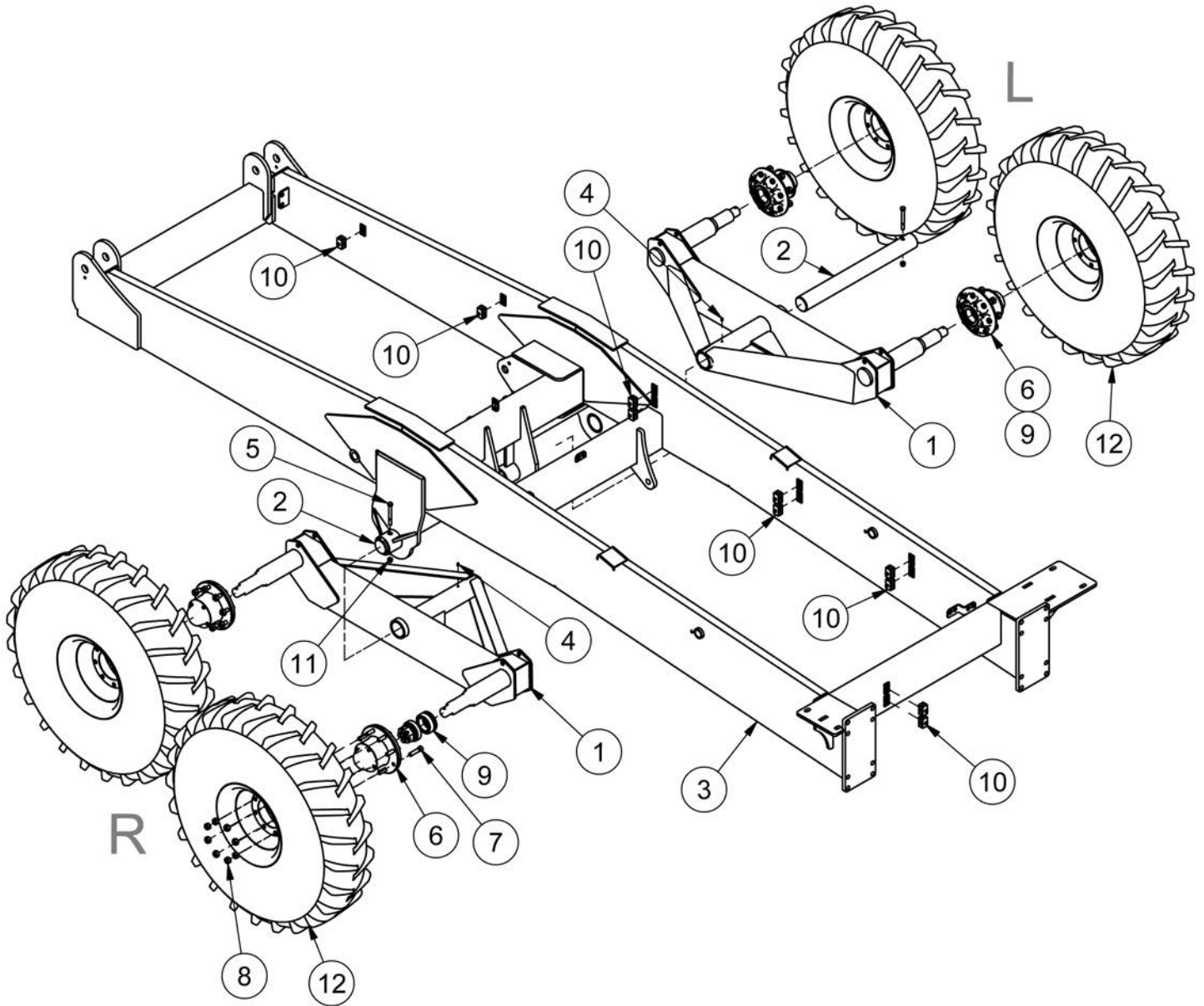

## Main Frame & Axles

ITEM	QTY	PART NUMBER	DESCRIPTION	NOTE
1	2	27583	505 Walking Beam Assembly	
2	2	27584	Walking Beam Pin	
3	1	27850W	Main Frame	
4	2	GR 1/4 X 28	Grease Fitting 1/4-28 Straight Standard Zerk	
5	2	HB1/2-13X4.5Z5	Hex Bolt 1/2-13x4 1/2 Grade 5 Zinc Plated Hex Cap Screw	
6	4	HUB 12000	Spreader Hub Model 450-600	Inc Items 7-9
7	8	31531	F58-2625 Wheel Stud	Qty per hub
8	8	31532	F58-18 Flange Nut	Qty per hub
9	1	HUB 12000-CCS	Complete Bearing and Seals for HUB12000	Qty per hub
10	10	LA-HOSE CLAMP	Hose Clamp - 3/8"	
11	2	LN1/2-13NCZ5	LN 1/2-13 Zinc Plated Nylon Insert Lock Nut	
12	4	WHE 12.4X24X8	12.4x24 8 Ply w/ 24x8 bolt rim 1.5 negative offset	Specify Left or Right

## Tongue - Up to SN 19B401

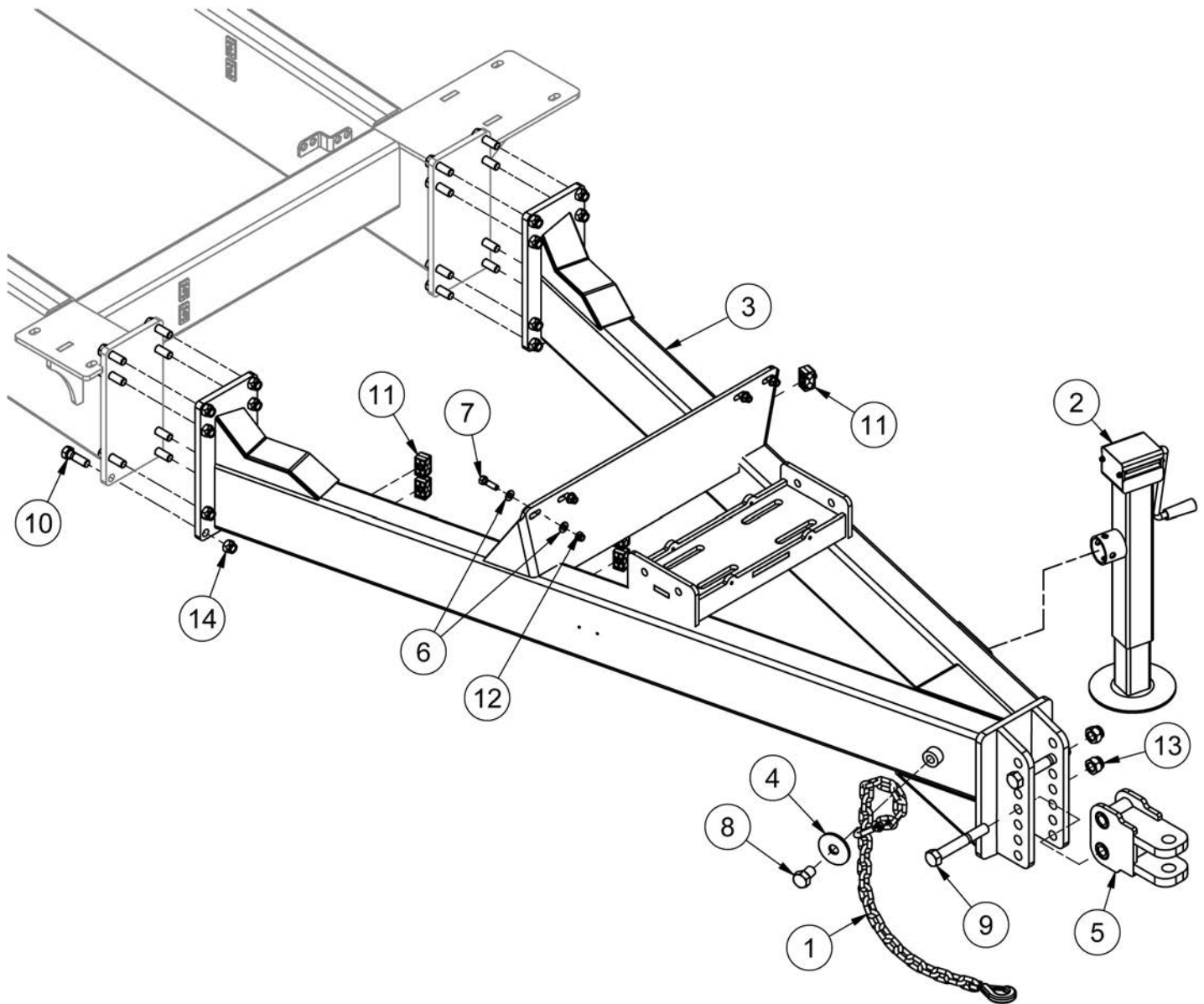

ITEM	QTY	PART NUMBER	DESCRIPTION
1	1	25262	Safety Chain 20000 # 60"
2	1	25719	Heavy Duty Jack
3	1	27852W	Hitch Assembly
4	1	28037	Retaining Washer
5	1	28053	Hitch
6	8	FW 1/2	Flatwasher - 1/2" Zinc Plated USS
7	4	HB1/2-13X1.75Z5	Hex Bolt 1/2-13x1 3/4 Grade 5 Zinc Plated Hex Cap Screw
8	1	HB1-8X1.5Z5	Hex Bolt 1-8x1 1/2 Grade 5 Zinc Plated Hex Cap Screw
9	2	HB1-8X7Z5	Hex Bolt 1-8x7 Grade 5 Zinc Plated Hex Cap Screw
10	16	HB3/4-10X2.5Z5	Hex Bolt 3/4-10x2 1/2 Grade 5 Zinc Plated Hex Cap Screw
11	5	LA-HOSE CLAMP	Hose Clamp - 3/8"
12	4	LN1/2-13NCZ5	LN 1/2-13 Zinc Plated Nylon Insert Lock Nut
13	2	LN1-8NCZ5	LN 1-8 Zinc Plated Nylon Insert Lock Nut
14	16	LN3/4-10NCZ5	LN 3/4-10 Zinc Plated Nylon Insert Lock Nut

## Tongue - SN 19B402 to Current

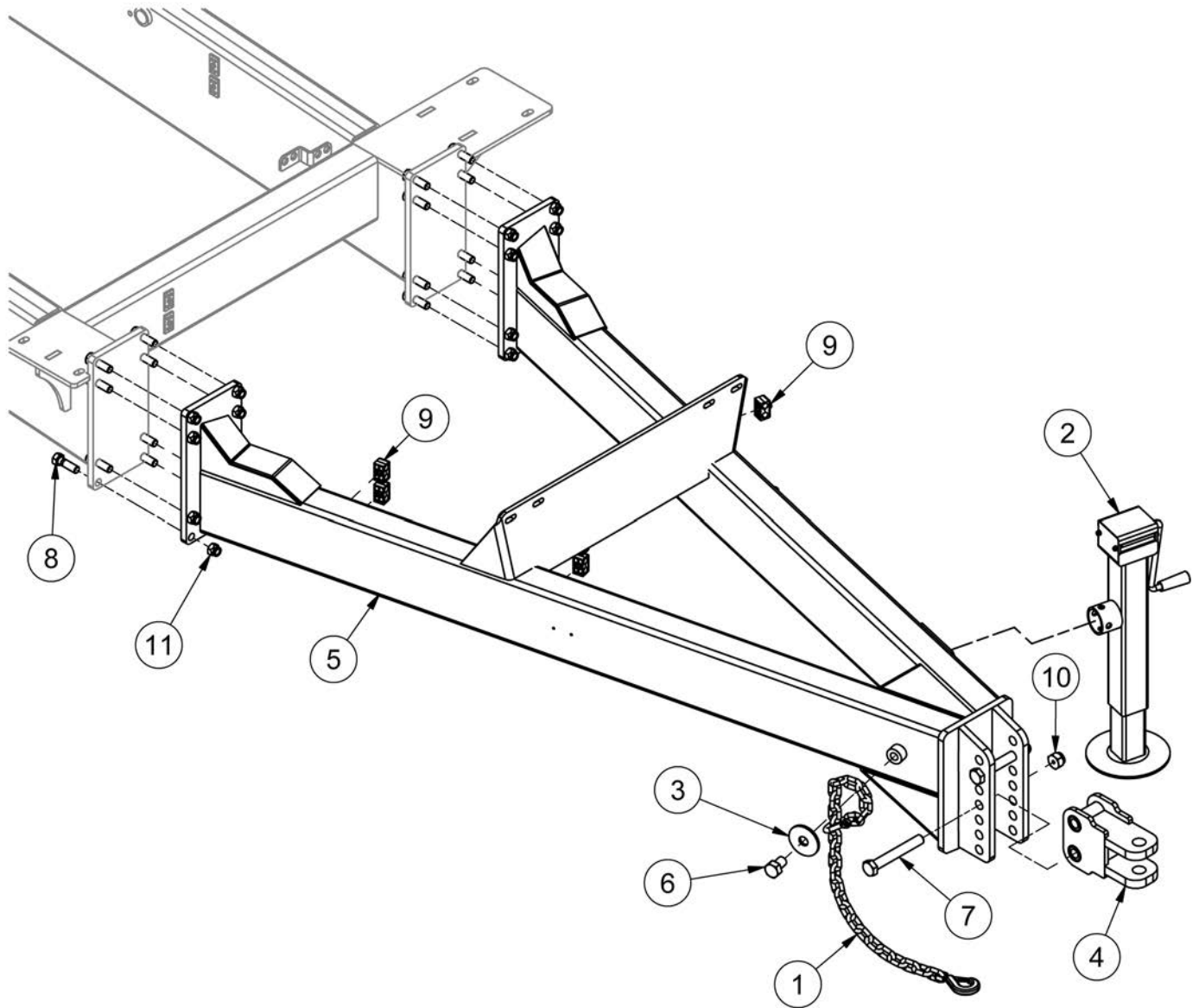

ITEM	QTY	PART NUMBER	DESCRIPTION
1	1	25262	Safety Chain 20000 # 60"
2	1	25719	Heavy Duty Jack
3	1	28037	Retaining Washer
4	1	28053	Hitch
5	1	47791	Hitch Assembly
6	1	HB1-8X1.5Z5	Hex Bolt 1-8x1 1/2 Grade 5 Zinc Plated Hex Cap Screw
7	2	HB1-14X7YZ8	Hex Bolt 1-14x7 Grade 8 Zinc Hex Cap Screw
8	16	HB3/4-10X2.5Z5	Hex Bolt 3/4-10x2 1/2 Grade 5 Zinc Plated Hex Cap Screw
9	5	LA-HOSE CLAMP	Hose Clamp - 3/8"
10	2	LN 1 F	Center Locknuts (1-14) 2-Way Fine Thread
11	16	LN3/4-10NCZ5	LN 3/4-10 Zinc Plated Nylon Insert Lock Nut

# Deck Frame

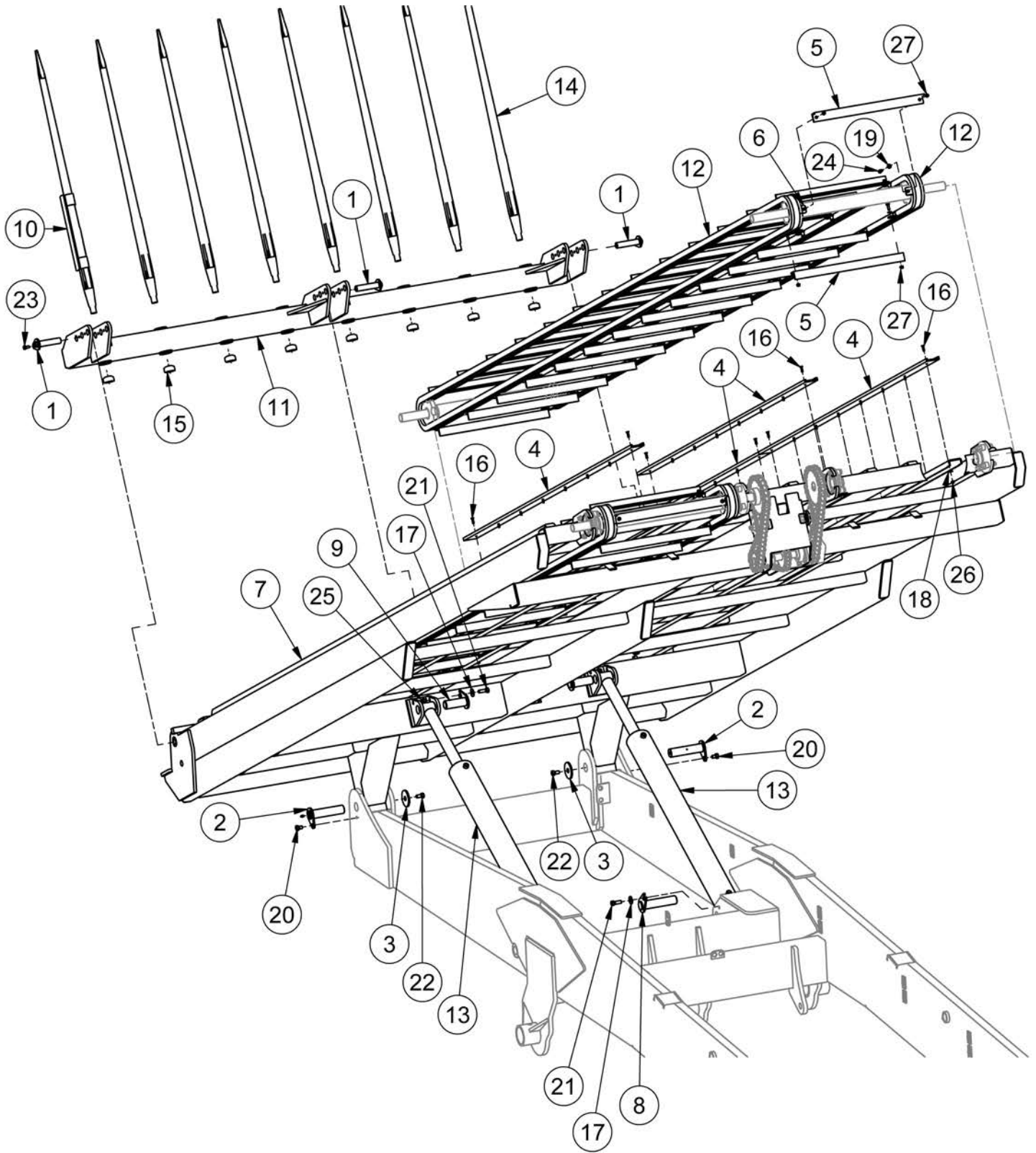

## Deck Frame

ITEM	QTY	PART NUMBER	DESCRIPTION
1	3	23355	1" PIN Linkage Retaining Pin
2	2	23478	1 1/2" X 6 1/4" Pin
3	2	23677	2" Pin Cap
4	8	27625	Chain Slide
5	54	27640	Slat
6	108	27761	Chain Tab
7	1	27853W	Deck
8	2	27857W	Deck Hinge/4"Cly Base Pin Assem.
9	2	27859W	4" Cyl Rod End Pin Assem
10	1	28084	Tine Knife
11	1	28770	Tine Hinge
12	4	CHAIN 81X	Bed Chain
13	2	CYL27558	Hydraulic Cylinder - 4" X 40" X 2"
14	8	LA-SDE49	Bale Spear - 49" Conus II
15	8	LA-SDENU	Conus II Nut
16	64	FHSCS1/4-20X1	Hex Bolt - 1/4"-20 x 1" Flat Socket Cap Screw
17	20	FW 1/2	Flatwasher - 1/2" Zinc Plated USS
18	32	FW 1/4	Flatwasher - 1/4" Zinc Plated USS
19	108	FW 5/16	Flatwasher - 5/16" Zinc Plated USS
20	2	HB1/2-13X0.75Z5	Hex Bolt 1/2-13x3/4 Gr.5 Zinc Plated Hex Cap Screw
21	4	HB1/2-13X1.5Z5	Hex Bolt 1/2-13x1 1/2 Gr.5 Zinc Plated Hex Cap Screw
22	2	HB1/2-13X1Z5	Hex Bolt 1/2-13x1 Gr.5 Zinc Plated Hex Cap Screw
23	3	HB3/8-16X0.75Z5	Hex Bolt 3/8-16x3/4 Gr.5 Zinc Plated Hex Cap Screw
24	108	HB5/16-18X1Z5	Hex Bolt 5/16-18x1 Gr.5 Zinc Plated Hex Cap Screw
25	56	LN1/2-13NCZ5	LN 1/2-13 Zinc Plated Nylon Insert Lock Nut
26	64	LN1/4-20NCZ5	LN 1/4-20 Zinc Plated Nylon Insert Lock Nut
27	108	LN5/16-18NCZ5	LN 5/16-18 Zinc Plated Nylon Insert Lock Nut



# Deck Drive

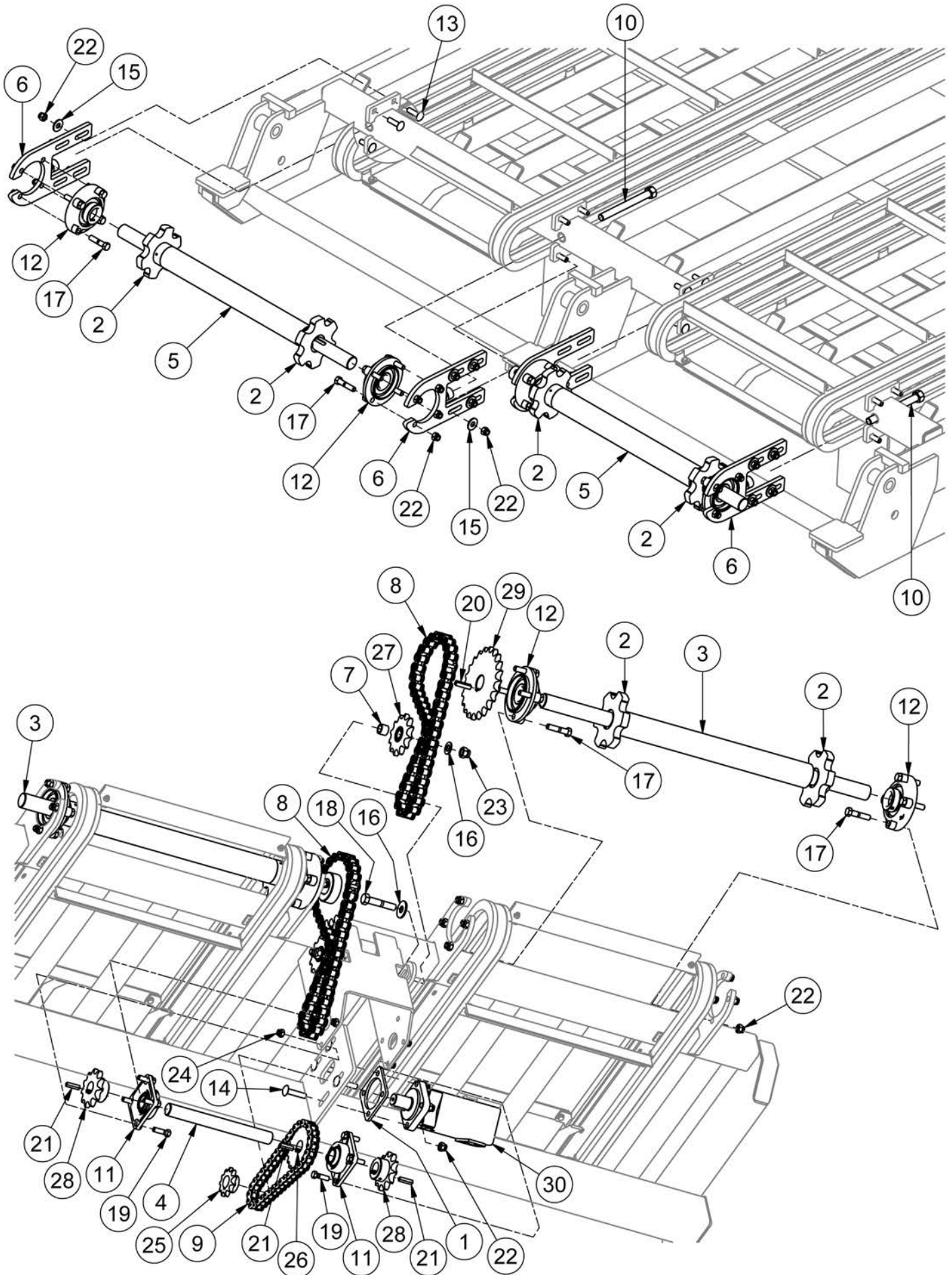

## Deck Drive

ITEM	QTY	PART NUMBER	DESCRIPTION
1	1	27759	Hyd Motor Spacer
2	8	27856W	81X Chain Sprocket
3	2	28098	Front Deck Shaft
4	1	28109	Jack Shaft
5	2	28147	Rear Deck Shaft
6	4	28796	Chain Adjuster
7	2	29679	Idler Sprocket Spacer
8	2	44805	Chain - #80 Single
9	2	44806	Chain - #60 Single
10	4	47717	Tensioner Rod
11	2	BEA UCF206-104	Flange Bearing, UCF206-104 National 4-Bolt 1.25"
12	8	BEA UCF208-24	1.5" Cartridge Bearing
13	16	CB1/2-13X1.75CZ5	Carriage Bolt - 1/2-13 x 1 3/4" Grade 5 Zinc
14	4	CB1/2-13X2.25CZ5	Carriage Bolt - 1/2-13 x 2 1/4" Grade 5 Zinc
15	17	FW 1/2	Flatwasher - 1/2" Zinc Plated USS
16	4	FW 5/8	Flatwasher - 5/8" Zinc Plated USS
17	32	HB1/2-13X2.25Z5	Hex Bolt 1/2-13x2 1/4 Gr.5 Zinc Plated Hex Cap Screw
18	2	HB5/8-11X3.25Z5	Hex Bolt 5/8-11x3 1/4 Gr.5 Zinc Plated Hex Cap Screw
19	8	HB7/16-14X1.5Z5	Hex Bolt 7/16-14x1 1/2 Grade 5 Zinc Plated Hex Cap Screw
20	2	KS41537	Key stock 3/8 X 3/8
21	3	KS49466	Keystock .313 X 1.75
22	53	LN1/2-13NCZ5	LN 1/2-13 Zinc Plated Nylon Insert Lock Nut
23	2	LN5/8-11NCZ5	LN 5/8-11 Zinc Plated Nylon Insert Lock Nut
24	8	LN7/16-14NCZ5	LN 7/16-14 Zinc Plated Nylon Insert Lock Nut
25	1	SPR60B111.25	11 tooth #60 Sprocket with Hub
26	1	SPR60B201.25	20 Tooth # 60 Sprocket with Hub
27	2	SPR80B12E12	80 12 Tooth Idler Sprocket with Bearing - 3/4 Bore
28	2	SPR80B111.25	#80 CHAIN 11 TOOTH
29	2	SPR80B221.5	#80 CHAIN 22 TOOTH
30	1	VAL MLHSY400	Complete Motor - MLHSY400C4UD

# Lift Assist

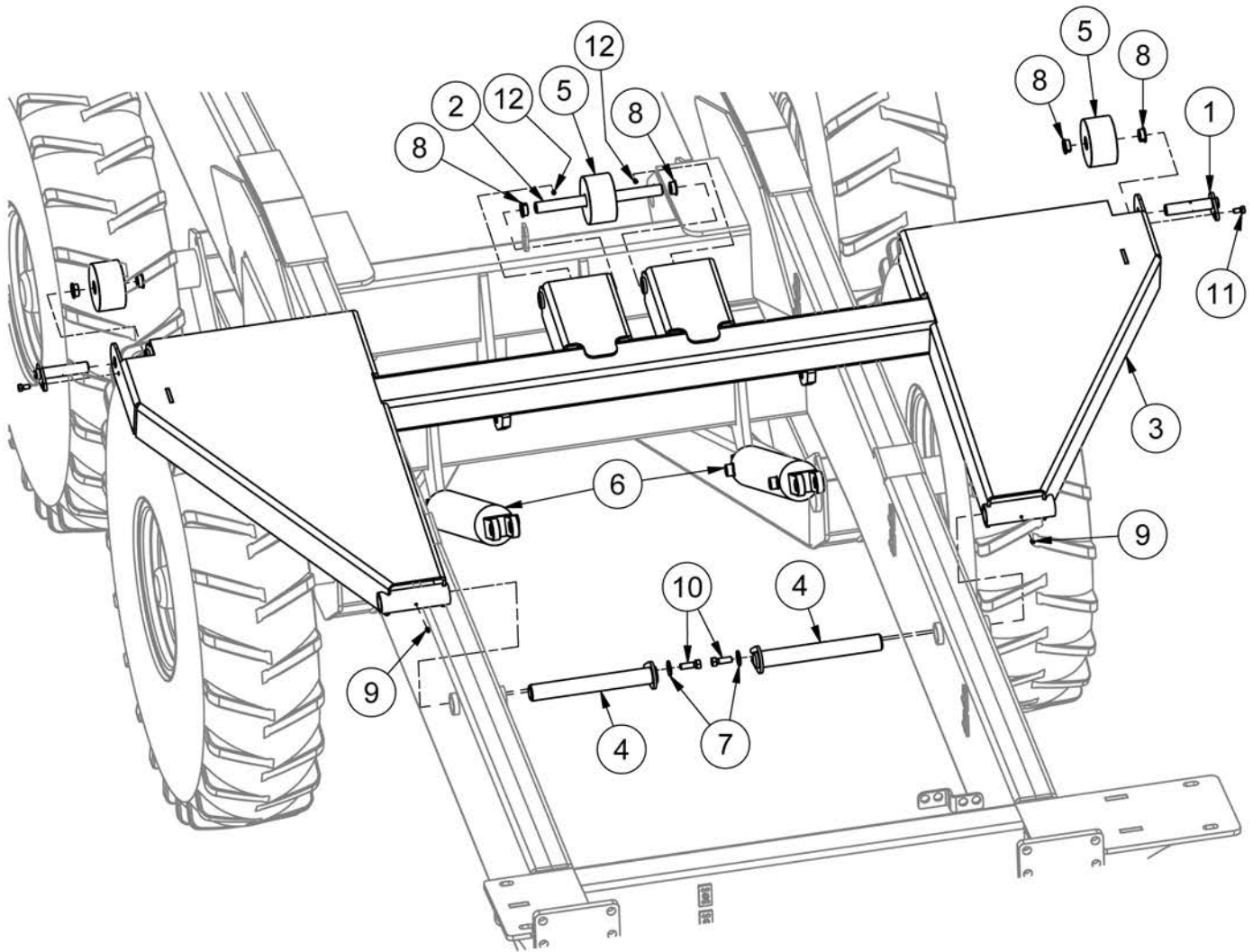

## Lift Assist

ITEM	QTY	PART NUMBER	DESCRIPTION
1	2	23355	Linkage Retaining Pin
2	1	27630	Middle Roller Pin
3	1	27854W	Lift Assist
4	2	27858W	L.A. Hinge Pin Assem.
5	3	28010	Roller
6	2	BS199899A	Hydraulic Cylinder - 3-1/2" X 20-1/2"
7	2	FW 1/2	Flatwasher - 1/2" Zinc Plated USS
8	6	GFI-1618-08	Plastic Bushing
9	2	GR 1/4 X 28	Grease Fitting 1/4-28 Straight Standard Zerk
10	2	HB1/2-13X1.5Z5	Hex Bolt 1/2-13x1 1/2 Gr.5 Zinc Plated Hex Cap Screw
11	2	HB3/8-16X0.75Z5	Hex Bolt 3/8-16x3/4 Gr.5 Zinc Plated Hex Cap Screw
12	2	SS5/16-18CX0.25CP	Allan Head Set Screw, 5/16-18 x 1/4

# Shredder - Up to SN 19B401

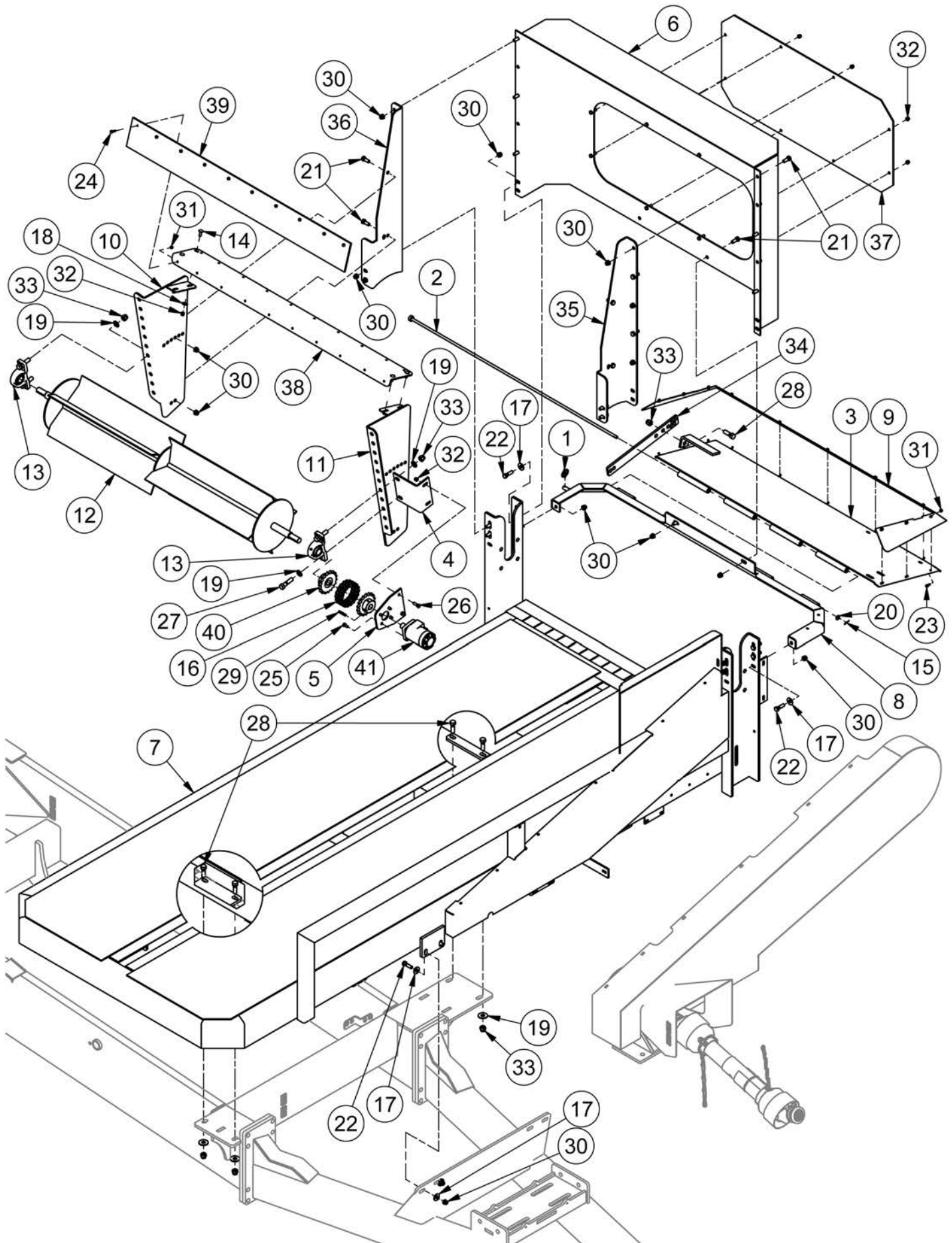

## Shredder - Up to SN 19B401

ITEM	QTY	PART NUMBER	DESCRIPTION
1	1	25680	Linch Pin 3/16 X 1.5
2	1	25735	Hinge Shaft
3	1	25754	Hinge Tab
4	1	27225	Top Beater Motor
5	1	27226	Top Beater Motor Mount
6	1	27233	Upper Hood
7	1	28020	Deck
8	1	200177	Outer Lid Support
9	1	208106	Side Discharge Deflector
10	1	BS208138	Right Inner Side Plate
11	1	BS208138M	Left Inner Side Plate
12	1	208139	Top Beater
13	2	BEA UCP207-20NTL	Bearing 1.25 Pillow Block Bearing
14	4	CB3/8-16X1CZ5	Carriage Bolt - 3/8-16 x 1" Grade 5 Zinc
15	1	CP 18X1	Pin, Cotter - 1/8" X 1.0"
16	1	D60-18L	Beater Coupler Chain
17	15	FW 1/2	Flatwasher - 1/2" Zinc Plated USS
18	4	FW 3/8	Flatwasher - 3/8" Zinc Plated USS
19	12	FW 5/8	Flatwasher - 5/8" Zinc Plated USS
20	1	FW 7/16	Flatwasher - 7/16" Zinc Plated USS
21	16	HB1/2-13X1.25Z5	Hex Bolt 1/2-13x1 1/4 Grade 5 Zinc Plated Hex Cap Screw
22	9	HB1/2-13X1.75Z5	Hex Bolt 1/2-13x1 3/4 Grade 5 Zinc Plated Hex Cap Screw
23	11	HB1/4-20X0.75Z5	Hex Bolt 1/4-20x3/4 Grade 5 Zinc Plated Hex Cap Screw
24	10	HB1/4-20X1Z5	Hex Bolt 1/4-20x1 Grade 5 Zinc Plated Hex Cap Screw
25	4	HB3/8-16X0.75Z5	Hex Bolt 3/8-16x3/4 Grade 5 Zinc Plated Hex Cap Screw
26	2	HB3/8-16X1.25Z5	Hex Bolt 3/8-16x1 1/4 Grade 5 Zinc Plated Hex Cap Screw
27	4	HB5/8-11X2.5Z5	Hex Bolt 5/8-11x2 1/2 Grade 5 Zinc Plated Hex Cap Screw
28	5	HB5/8-11X2Z5	Hex Bolt 5/8-11x2 Grade 5 Zinc Plated Hex Cap Screw
29	1	KS40960	Key .25 x 1.75
30	31	LN1/2-13NCZ5	LN 1/2-13 Zinc Plated Nylon Insert Lock Nut
31	21	LN1/4-20NCZ5	LN 1/4-20 Zinc Plated Nylon Insert Lock Nut
32	14	LN3/8-16NCZ5	LN 3/8-16 Zinc Plated Nylon Insert Lock Nut
33	9	LN5/8-11NCZ5	LN 5/8-11 Zinc Plated Nylon Insert Lock Nut
34	1	PCT200002	Deflector Adjuster
35	1	PCT200172L	Left Side Adjuster Plate
36	1	PCT200172R	Right Side Adjustable Plate
37	1	PCT200174	Upper Hood Cover
38	1	PCT200175	Roof Top Plate Cover
39	1	PCT200190	Rubber Shield
40	2	SPR60B18	60B18 Sprocket w/1 Bore 1/4 kwy
41	1	VAL 1005	Motor, 101-1005-009 Hydraulic Motor

# Shredder - SN 19B402 to Current

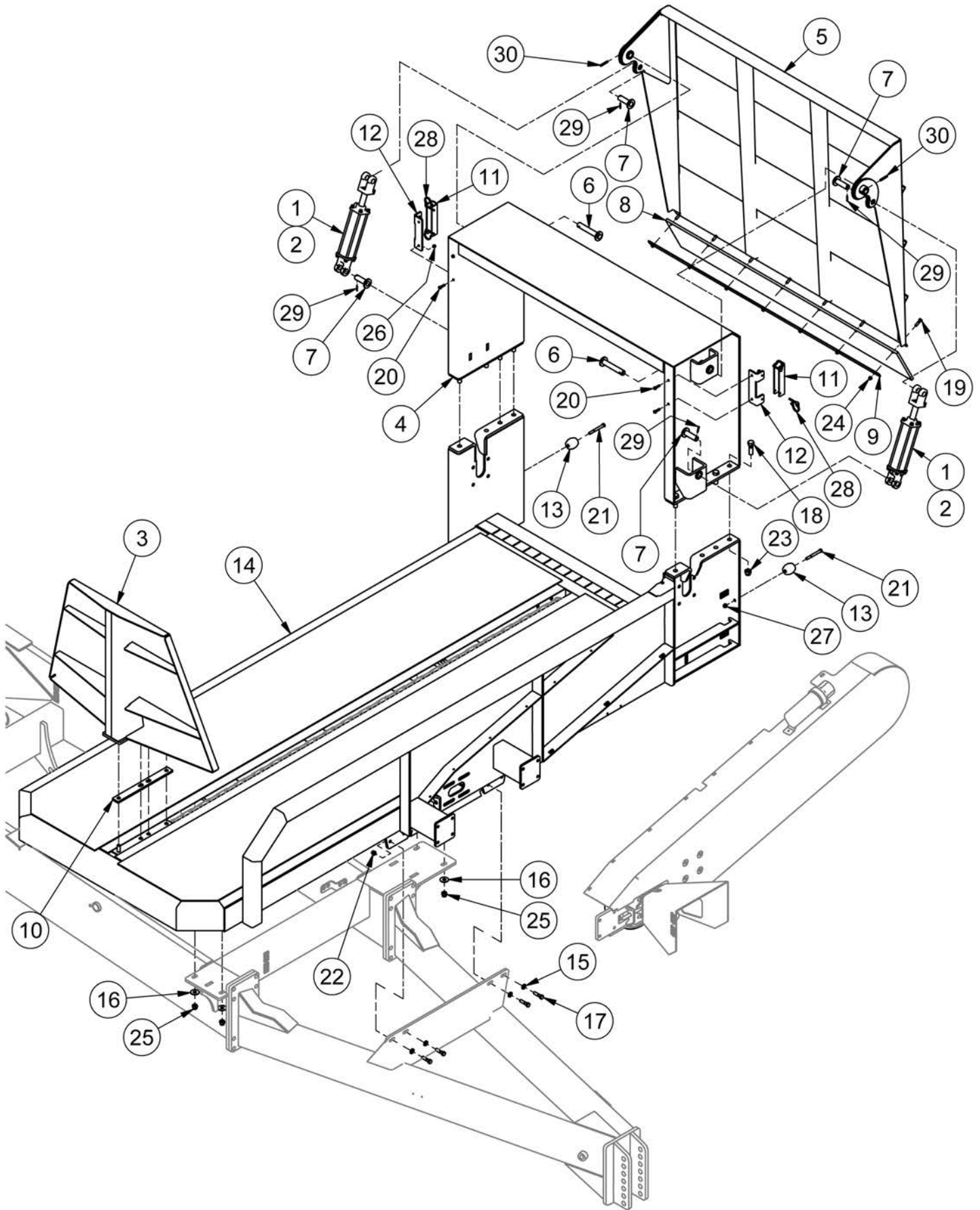

## Shredder - SN 19B402 to Current

ITEM	QTY	PART NUMBER	DESCRIPTION
1	2	TL500-100-082	Hydraulic Cylinder 2.5" Bore x 8" Stroke Adjustable Clevis
2	2	SK25-80	TL500-100-082 Seal Kit
3	1	37546	Bale Pusher Plate
4	1	39001	Top Frame
5	1	39006	Deflector Shield
6	2	39009	Cylinder Pin
7	4	39010	Cylinder Pin
8	1	39088	Rubber Deflector
9	1	39089	Rubber Deflector Hold Down
10	1	39811	Bale Pusher Guide
11	2	39876	Cylinder Channel Lock
12	2	39878	Cylinder Lock Mounting Shelf
13	2	40950	Timbren Rubber Spring
14	1	44809	Boss IV Shredder Base - 2019
15	4	FW 1/2	Flatwasher - 1/2" Zinc Plated USS
16	4	FW 5/8	Flatwasher - 5/8" Zinc Plated USS
17	4	HB1/2-13X2Z5	Hex Bolt 1/2-13x2 Grade 5 Zinc Plated Hex Cap Screw
18	8	HB3/4-10X2.5Z5	Hex Bolt 3/4-10x2 1/2 Grade 5 Zinc Plated Hex Cap Screw
19	7	HB3/8-16X1.5Z5	Hex Bolt 3/8-16x1 1/2 Grade 5 Zinc Plated Hex Cap Screw
20	4	HB5/16-18X1.25Z5	Hex Bolt 5/16-18x1 1/4 Grade 5 Zinc Plated Hex Cap Screw
21	2	HB7/16-14X4Z5	Hex Bolt 7/16-14x4 Grade 5 Zinc Plated Hex Cap Screw
22	5	LN1/2-13NCZ5	LN 1/2-13 Zinc Plated Nylon Insert Lock Nut
23	8	LN3/4-10NCZ5	LN 3/4-10 Zinc Plated Nylon Insert Lock Nut
24	8	LN3/8-16NCZ5	LN 3/8-16 Zinc Plated Nylon Insert Lock Nut
25	10	LN5/8-11NCZ5	LN 5/8-11 Zinc Plated Nylon Insert Lock Nut
26	4	LN5/16-18NCZ5	LN 5/16-18 Zinc Plated Nylon Insert Lock Nut
27	2	LN7/16-14NCZ5	LN 7/16-14 Zinc Plated Nylon Insert Lock Nut
28	4	LP B1995	Pin - Lock Pin 1/4 X 1 3/4
29	4	RP 3/16 x 1 1/4	Pin - Roll Pin 3/16 x 1 1/4
30	2	RP 5/16 x 2	Pin - Roll Pin 5/16 x 2



# Shredder Chain Drive - Up to SN 19B401

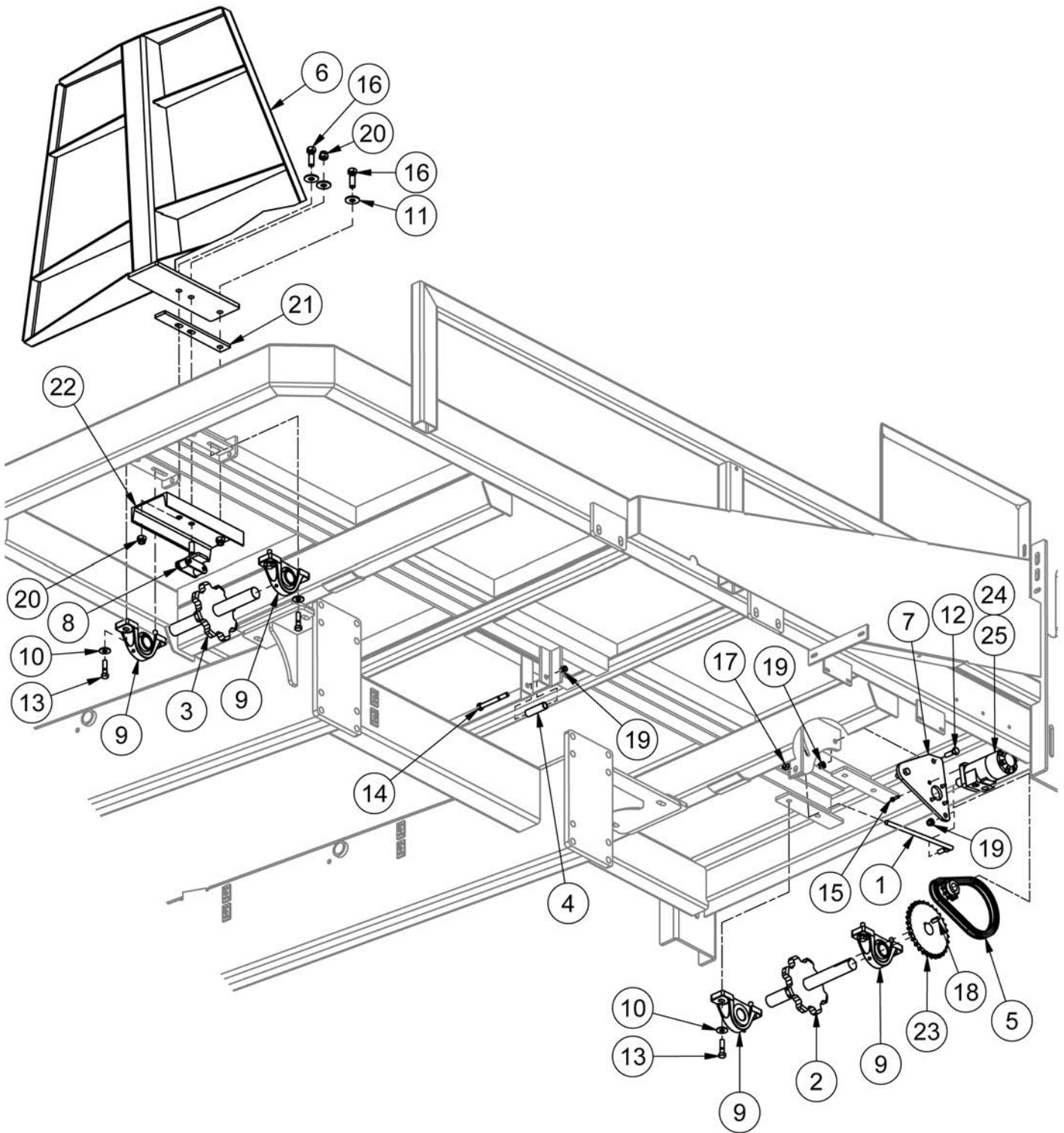

## Shredder Chain Drive - Up to SN 19B401

ITEM	QTY	PART NUMBER	DESCRIPTION
1	1	27232	Chain Tightener
2	1	27263	Ram Sprocket
3	1	27264	Ram Idler
4	1	30268	Chain Roller
5	1	39997	Bed Drive Chain
6	1	200003	Bale Pusher
7	1	208119A	Ram Motor Mount
8	1	B1 089	Chain Pusher Mount
9	4	BEA P208-108DI	Pillow Block NTN 2B 1.5"
10	10	FW 1/2	Flatwasher - 1/2" Zinc Plated USS
11	3	FW 5/8	Flatwasher - 5/8" Zinc Plated USS
12	2	HB1/2-13X1.5Z5	Hex Bolt 1/2-13x1 1/2 Grade 5 Zinc Plated Hex Cap Screw
13	8	HB1/2-13X2Z5	Hex Bolt 1/2-13x2 Grade 5 Zinc Plated Hex Cap Screw
14	1	HB1/2-13X4.5Z5	Hex Bolt 1/2-13x4 1/2 Grade 5 Zinc Plated Hex Cap Screw
15	4	HB1/4-20X1Z5	Hex Bolt 1/4-20x1 Grade 5 Zinc Plated Hex Cap Screw
16	2	HB5/8-11X2Z5	Hex Bolt 5/8-11x2 Grade 5 Zinc Plated Hex Cap Screw
17	1	HN1/2-13CZ5	Hex Nut 1/2"-13 Grade 5 Zinc Plated Finished
18	1	KS39999	Keystock .375 X .375 X 1
19	12	LN1/2-13NCZ5	LN 1/2-13 Zinc Plated Nylon Insert Lock Nut
20	3	LN5/8-11NCZ5	LN 5/8-11 Zinc Plated Nylon Insert Lock Nut
21	1	PCT200001	Bale Pusher Guide
22	1	SAW200013	Bale Pusher Mount
23	1	SPR60B30F-IH	Sprocket - 60B30F 1 1/2" KW 2SS
24	1	VAL 1008	Motor, Hydraulic - EAT101-1008-009
25	1	SKMLHPQUDE	Seal Kit for 200 & 400 Series Motors

# Shredder Chain Drive - SN 19B402 to Current

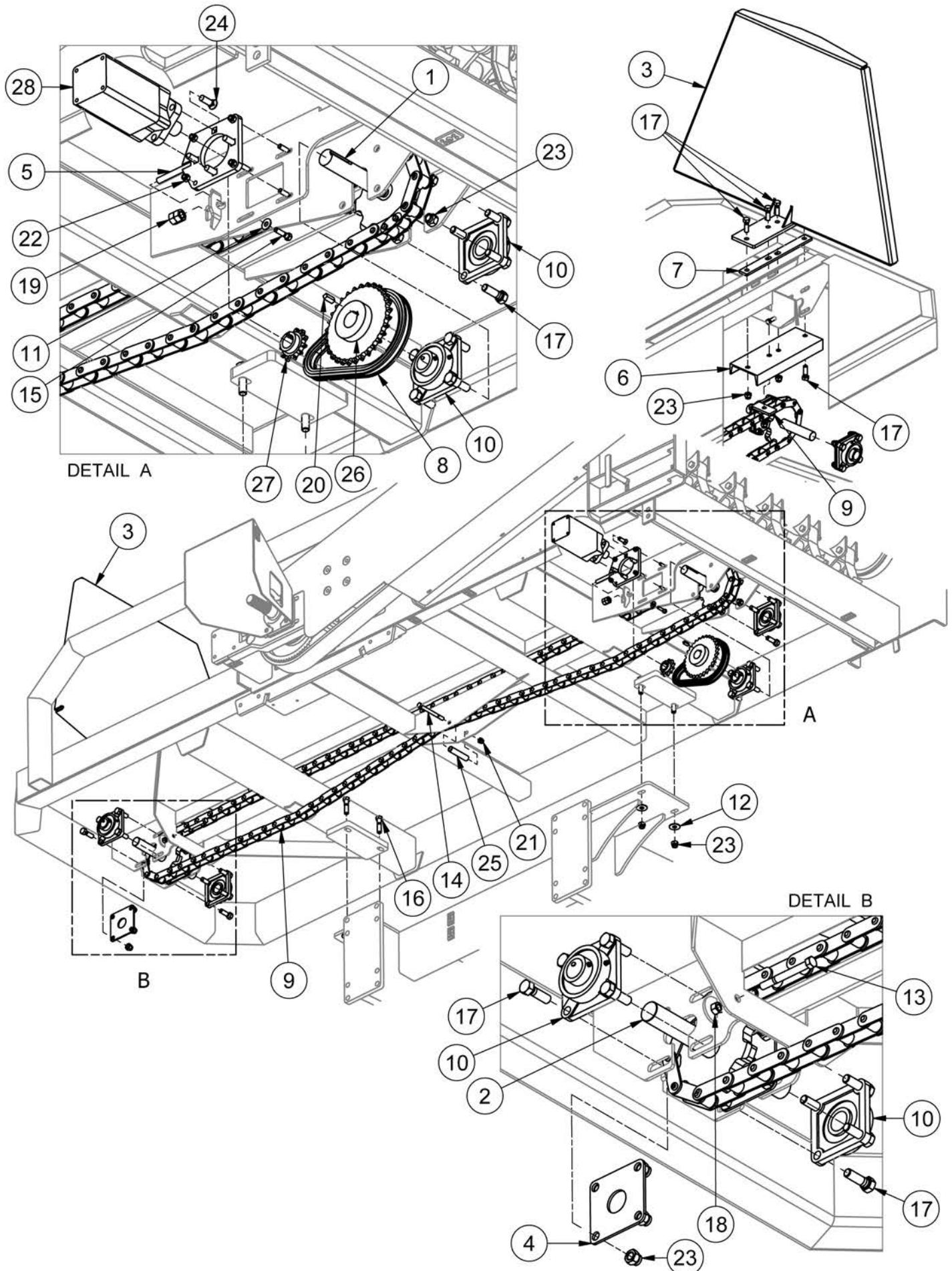

## Shredder Chain Drive - SN 19B402 to Current

ITEM	QTY	PART NUMBER	DESCRIPTION
1	1	27263	Ram Sprocket
2	1	27264	Ram Idler
3	1	37546	Bale Push Plate
4	2	37619	Spacer
5	1	39008	Ram Motor Plate
6	1	39085	Bale Pusher Mount
7	1	39811	Bale Pusher Guide
8	1	39997	Bed Chain - #60, 38 Links
9	1	44816	Boss IV Ram Chain - 2019
10	4	BEA UCF208-24-1.5	1 1/2" 4 Bolt Flange Bearing
11	4	FW 3/8	Flatwasher - 3/8" Zinc Plated USS
12	4	FW 5/8	Flatwasher - 5/8" Zinc Plated USS
13	2	HB1/2-13X4.5Z5	Hex Bolt 1/2-13x4 1/2 Grade 5 Zinc Plated Hex Cap Screw
14	1	HB1/2-13X5.5Z5	Hex Bolt 1/2-13x5 1/2 Grade 5 Zinc Plated Hex Cap Screw
15	4	HB3/8-16X1.5Z5	Hex Bolt 3/8-16x1 1/2 Grade 5 Zinc Plated Hex Cap Screw
16	4	HB5/8-11X2.5Z5	Hex Bolt 5/8-11x2 1/2 Grade 5 Zinc Plated Hex Cap Screw
17	20	HB5/8-11X2Z5	Hex Bolt 5/8-11x2 Grade 5 Zinc Plated Hex Cap Screw
18	2	HN1/2-13CZ5	Hex Nut 1/2"-13 Grade 5 Zinc Plated Finished
19	2	HN5/8-11CZ5	Hex Nut 5/8"-11 Grade 5 Zinc Plated Finished
20	1	KS39999	Keystock .375 X .375 X 1
21	1	LN1/2-13NCZ5	LN 1/2-13 Zinc Plated Nylon Insert Lock Nut
22	4	LN3/8-16NCZ5	LN 3/8-16 Zinc Plated Nylon Insert Lock Nut
23	23	LN5/8-11NCZ5	LN 5/8-11 Zinc Plated Nylon Insert Lock Nut
24	4	PB 1/2-13X1.5	Plow Bolts - 1/2-13 x 1 1/2 Flat Head Gr.5
25	1	SAW200040	Tee Handle, Chain Roller
26	1	SPR60B30F-IH	Sprocket - 60B30F 1 1/2" KW 2SS
27	1	SPR60B111.25	60B11 Sprocket w/1.25 Bore 5/16 kwy 2 5/16 SS
28	1	VAL MLHSY400	Complete Motor - MLHSY400C4UD

# Shredder Flail Drum - Up to SN 19B401

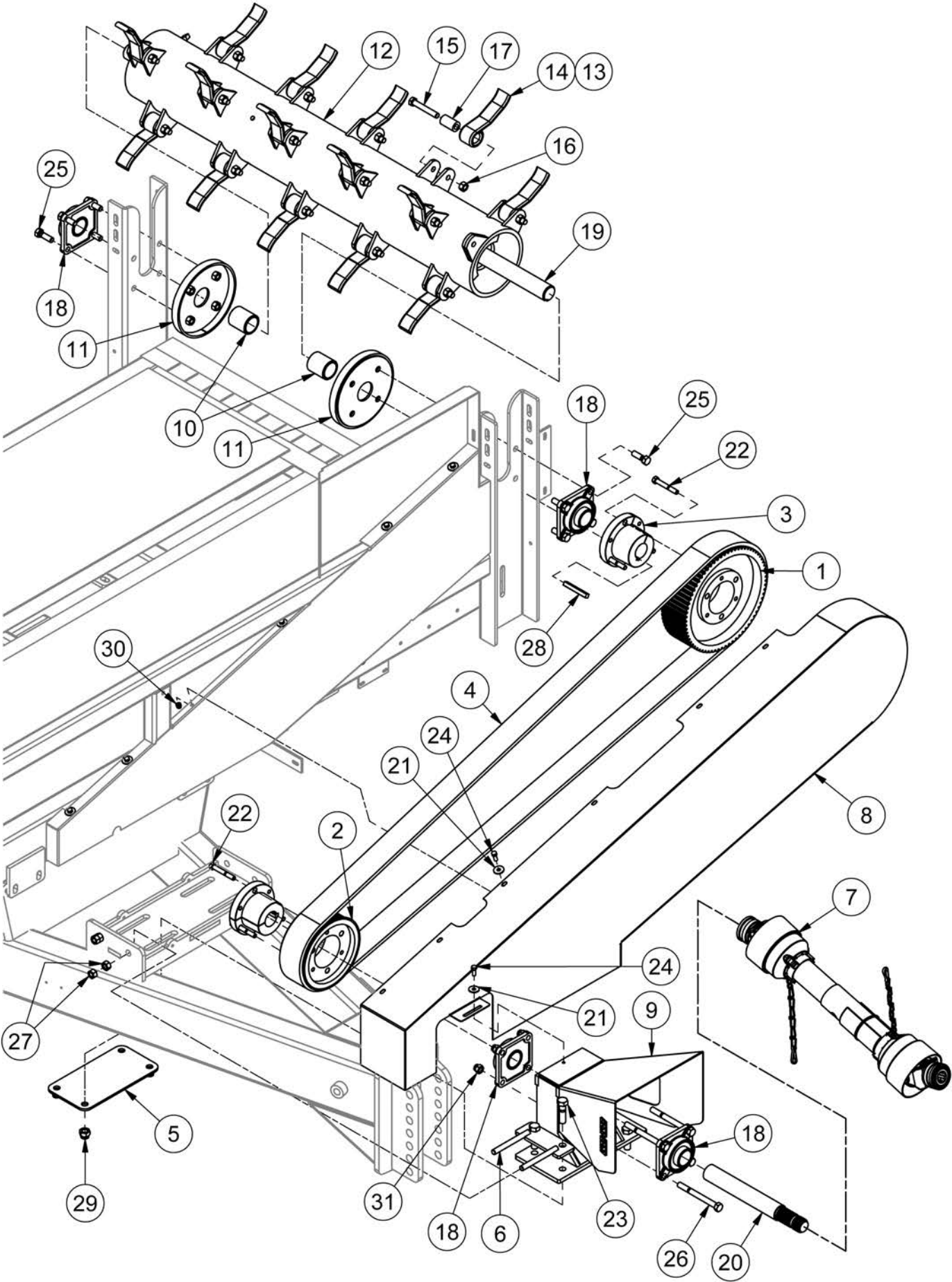

## Shredder Flail Drum - Up to SN 19B401

ITEM	QTY	PART NUMBER	DESCRIPTION	NOTE
1	1	28005	Top Pulley	
2	1	28006	Bottom Pulley	
3	2	28007	Taper Lock	
4	1	28008	Drive Belt	
5	1	28232	Belt Guard	
6	1	28785	PTO Box Adjuster	
7	1	28787	PTO Boss IV 57' Long Closed - 1.75-20SB 1.75-20QD	
8	1	28930	Belt Guard	
9	1	29017	PTO Shield	
10	2	30264	Flail Drum Spacer	
11	2	208141	Bearing Protector	
12	1	208142	Bottom Beater	Inc Item 12
13	20	25574	Flail Assembly	Items 14-17
14	1	CMP200113	Flail	
15	1	HB 5/8-18 X4 YZ8	Hex Bolt 5/8-18x4 Grade 8 Zinc Hex Cap Screw	
16	1	HN 5/8 - 18	Hex Nut 5/8-18 NF Fine Thread	
17	1	SAW200059	Flail Bushing	
18	4	BEA UCF210-32R3	2" Bearing 4-Bolt Ductile Iron Flange with Triple Seal	
19	1	PCT200057	Main Beater Shaft	
20	1	PCT200163	PTO Drive Shaft	
21	8	FW 3/8	Flatwasher - 3/8" Zinc Plated USS	
22	6	HB1/2-13X3.5Z5	Hex Bolt 1/2-13x3 1/2 Grade 5 Zinc Plated Hex Cap Screw	
23	2	HB3/4-10X2.75Z5	Hex Bolt 3/4-10x2 3/4 Grade 5 Zinc Plated Hex Cap Screw	
24	8	HB3/8-16X1Z5	Hex Bolt 3/8-16x1 Grade 5 Zinc Plated Hex Cap Screw	
25	8	HB5/8-11X2Z5	Hex Bolt 5/8-11x2 Grade 5 Zinc Plated Hex Cap Screw	
26	4	HB5/8-11X6.5Z5	Hex Bolt 5/8-11x6 1/2 Grade 5 Zinc Plated Hex Cap Screw	
27	4	HN5/8-11CZ5	Hex Nut 5/8"-11 Grade 5 Zinc Plated Finished	
28	2	KS49463	Keystock .5 X 3.75	
29	4	LN3/4-10NCZ5	LN 3/4-10 Zinc Plated Nylon Insert Lock Nut	
30	5	LN3/8-16NCZ5	LN 3/8-16 Zinc Plated Nylon Insert Lock Nut	
31	4	LN5/8-11NCZ5	LN 5/8-11 Zinc Plated Nylon Insert Lock Nut	

# Shredder Flail Drum - SN 19B402 to Current

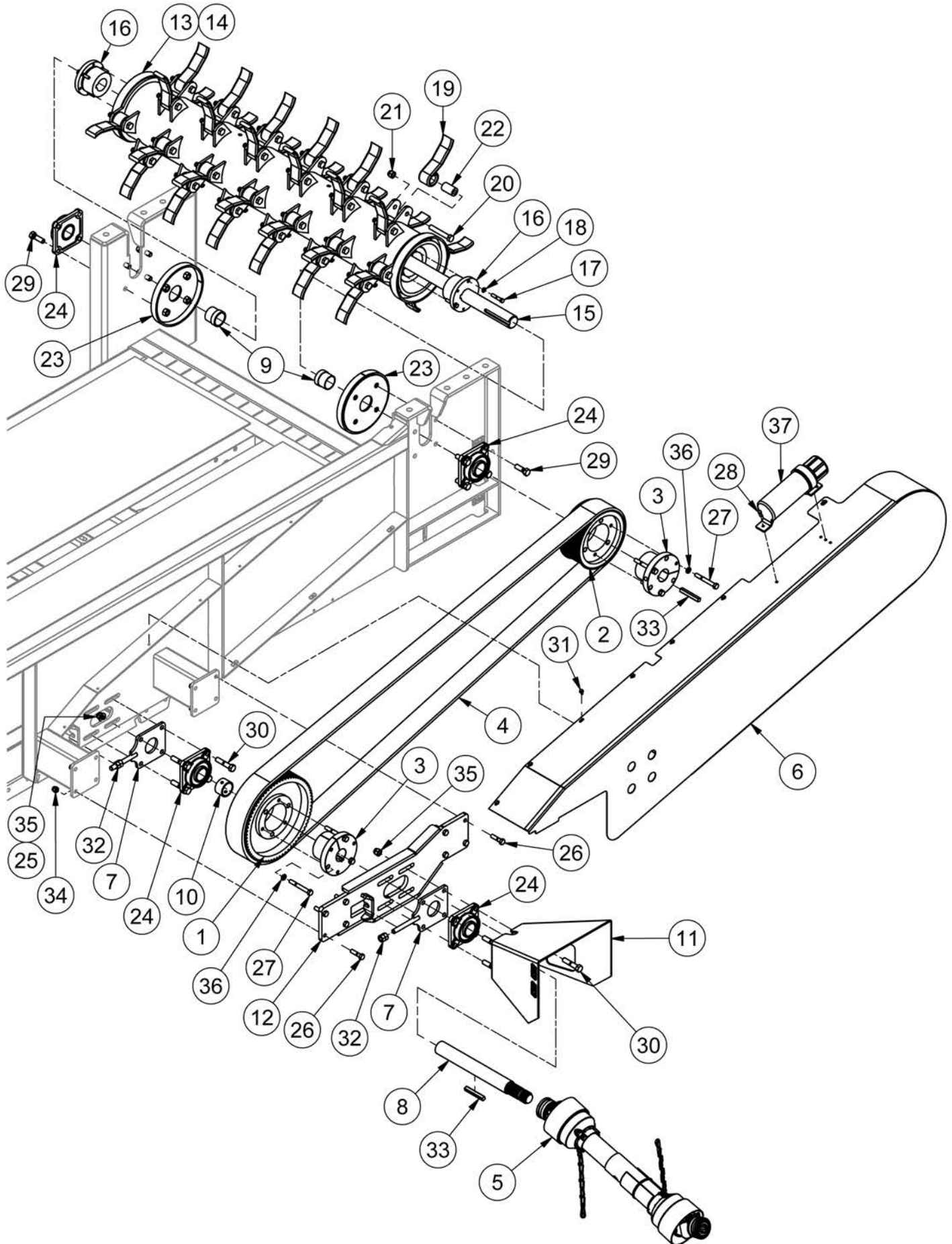

## Shredder Flail Drum - SN 19B402 to Current

ITEM	QTY	PART NUMBER	DESCRIPTION	NOTE
1	1	28005	Top Pulley	
2	1	28006	Bottom Pulley	
3	2	28007	Taper Lock	
4	1	28008	Drive Belt	
5	1	28787	PTO Boss IV 57' Long Closed - 1.75-20SB 1.75-20QD	
6	1	39005	Belt Shield	
7	2	39007	Pulley Bearing Adjuster	
8	1	39086	PTO Drive Shaft	
9	2	39102	Beater Shaft Spacer	
10	1	39104	Back Beater Shaft Spacer	
11	1	40985	PTO Shield	
12	1	41446	Pulley Bearing Mount	
13	1	50079	Boss II HD Drum (w/flails)	Inc. Items 14-22
14	1	50080	Boss II Flail Beater Weldment	
15	1	37789	Main Beater Shaft	
16	2	46982	R1x2" Split Taper Bushing	
17	6	HB3/8-16X2Z5	Hex Bolt 3/8-16x2 Grade 5 Zinc Plated Hex Cap Screw	
18	6	LW 3/8	LW - 3/8" Zinc Plated Medium Split	
19	38	CMP200113	Flail	
20	38	HB 5/8-18 X4 YZ8	Hex Bolt 5/8-18x4 Grade 8 Zinc Hex Cap Screw	
21	38	LN 5/8 F	Center Locknuts (5/8-18) 2-Way Fine Thread	
22	38	Saw200059	Flail Bushing	
23	2	208141	Bearing Protector	
24	4	BEA UCF210-32R3	2" Bearing 4-Bolt Ductile Iron Flange with Triple Seal	
25	4	FW 5/8	Flatwasher - 5/8" Zinc Plated USS	
26	8	HB1/2-13X2Z5	Hex Bolt 1/2-13x2 Grade 5 Zinc Plated Hex Cap Screw	
27	6	HB1/2-13X4Z5	Hex Bolt 1/2-13x4 Grade 5 Zinc Plated Hex Cap Screw	
28	2	HB1/4-20X0.75Z5	Hex Bolt 1/4-20x3/4 Grade 5 Zinc Plated Hex Cap Screw	
29	8	HB5/8-11X2Z5	Hex Bolt 5/8-11x2 Grade 5 Zinc Plated Hex Cap Screw	
30	8	HB5/8-11X3Z5	Hex Bolt 5/8-11x3 Grade 5 Zinc Plated Hex Cap Screw	
31	10	HBC1/4X0.5	Hex Bolt Cerrated 1/4-20 x 1/2 Zinc Flange Bolt	
32	4	HN5/8-11CZ5	Hex Nut 5/8"-11 Grade 5 Zinc Plated Finished	
33	2	KS49463	Keystock .5 X 3.75	
34	8	LN1/2-13NCZ5	LN 1/2-13 Zinc Plated Nylon Insert Lock Nut	
35	8	LN5/8-11NCZ5	LN 5/8-11 Zinc Plated Nylon Insert Lock Nut	
36	6	LW 1/2	LW -1/2" Zinc Plated Medium Split	
37	1	TL5X2-201-111	Operator's Manual Holder	



# Section 5: Hydraulics

## Hydraulic Layout - Up to SN 19B401

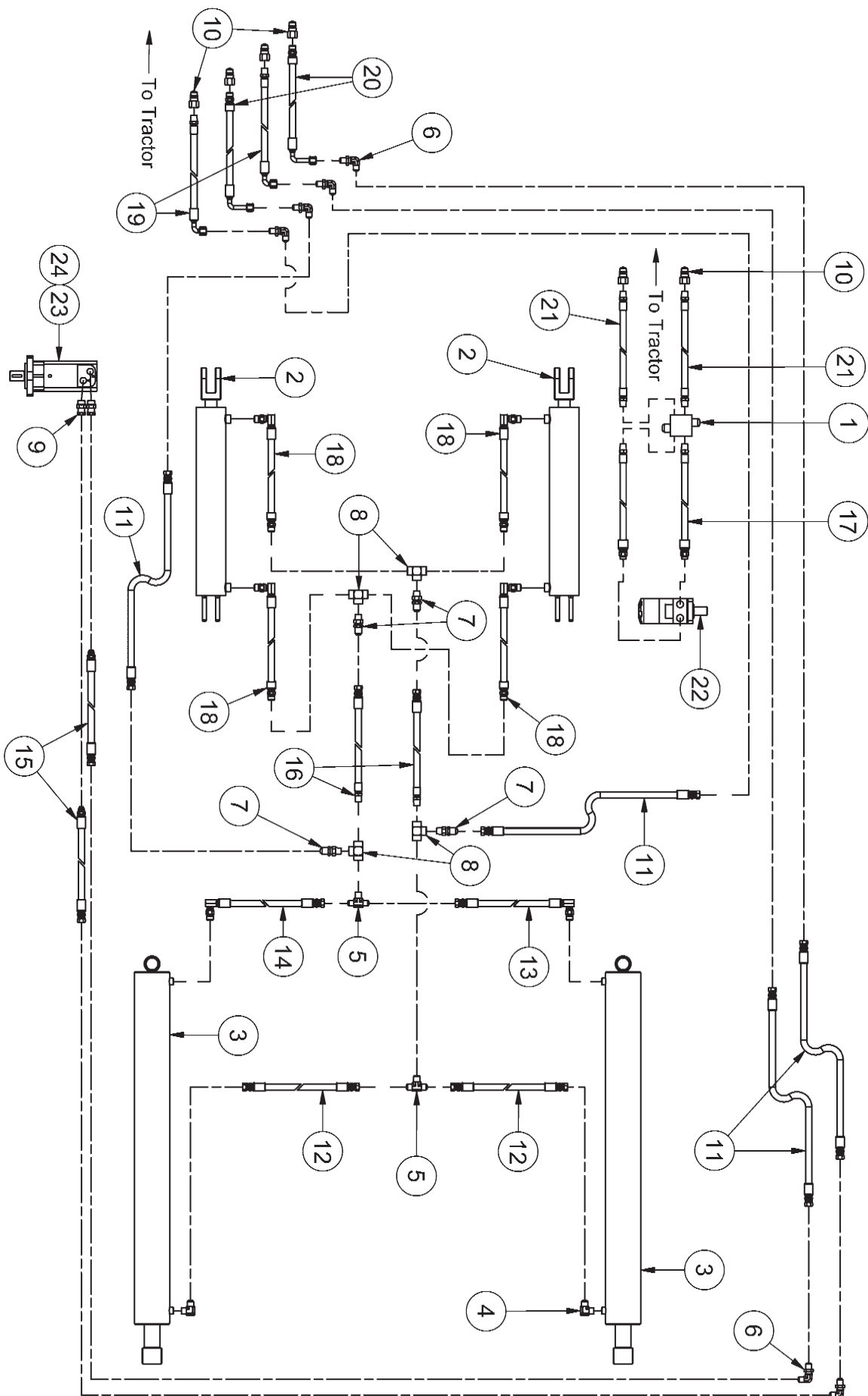

## Hydraulic Layout - Up to SN 19B401

ITEM	QTY	PART NUMBER	DESCRIPTION
1	1	26215	Cross Over Relief 1/2" - 4 Port
2	2	BS199899A	Hydraulic Cylinder - 3-1/2" X 20-1/2"
3	2	CYL27558	Hydraulic Cylinder - 4" X 40" X 2"
4	2	HF 2501-8-8	Hydraulic Elbow - 1/2" ORB to 1/2" MJIC
5	2	HF 2601-8-8-8	JIC to Pipe Branch Tee
6	6	HF 2701LN-8-8	Hyd. Fitting 1/2" MJIC Bulkhead 90° Long
7	4	HF 2706LN-8-8	Bulkhead Fitting - 1/2" Pipe - 1/2" MJIC
8	4	HF 5605-8	Female Pipe Tee 1/2"
9	2	HF 6402-10-8	Hyd. Fitting #10 Male O-Ring to #8 F JIC
10	6	HF 8010-4	Quickcoupler 1/2" Male Tip
11	4	28237	Hose - HH139 - 8AT1(8FJXH,8FJXH) HCL 139"
12	2	28238	Hose - HH67 - 8AT1(8FJXH,8FJXH) HCL67
13	1	26913	Hose - HH60 - 8AT1(8FJXH,8MBX90) HCL 60"
14	1	28029	Hose - HH192 - 8AT1(8FJXH,8FJXH)HCL 192"
15	2	28241	Hose - HH188 - 8AT1(8MJ,8FJXH) HCL 188"
16	2	28236	Hose - HH18 - 8AT1(8FJXH,8MP) HCL 18"
17	2	28239	Hose - HH87 - 8AT1(8FJXH,8MP) HCL 87
18	4	28240	Hose - HH39 - 8AT1(8MBX90,8MP) HCL 39"
19	2	28234	Hose - HH180 - 8AT1(8MP,8FJXH90S) HCL 180"
20	2	28235	Hose - HH180 - 8AT1(8MP,8FJXH90L) HCL 180"
21	2	28233	Hose - HH86 - 8AT1(8MP,8MP) HCL 86"
22	1	VAL 1008	Motor, Hydraulic - EAT101-1008-009
23	1	VAL MLHSY400	Complete Motor - MLHSY400C4UD
24	1	SKMLHSY-U/D	Seal Kit for M+S Motors

# Hydraulic Layout - Wagon - SN 19B402 to Current

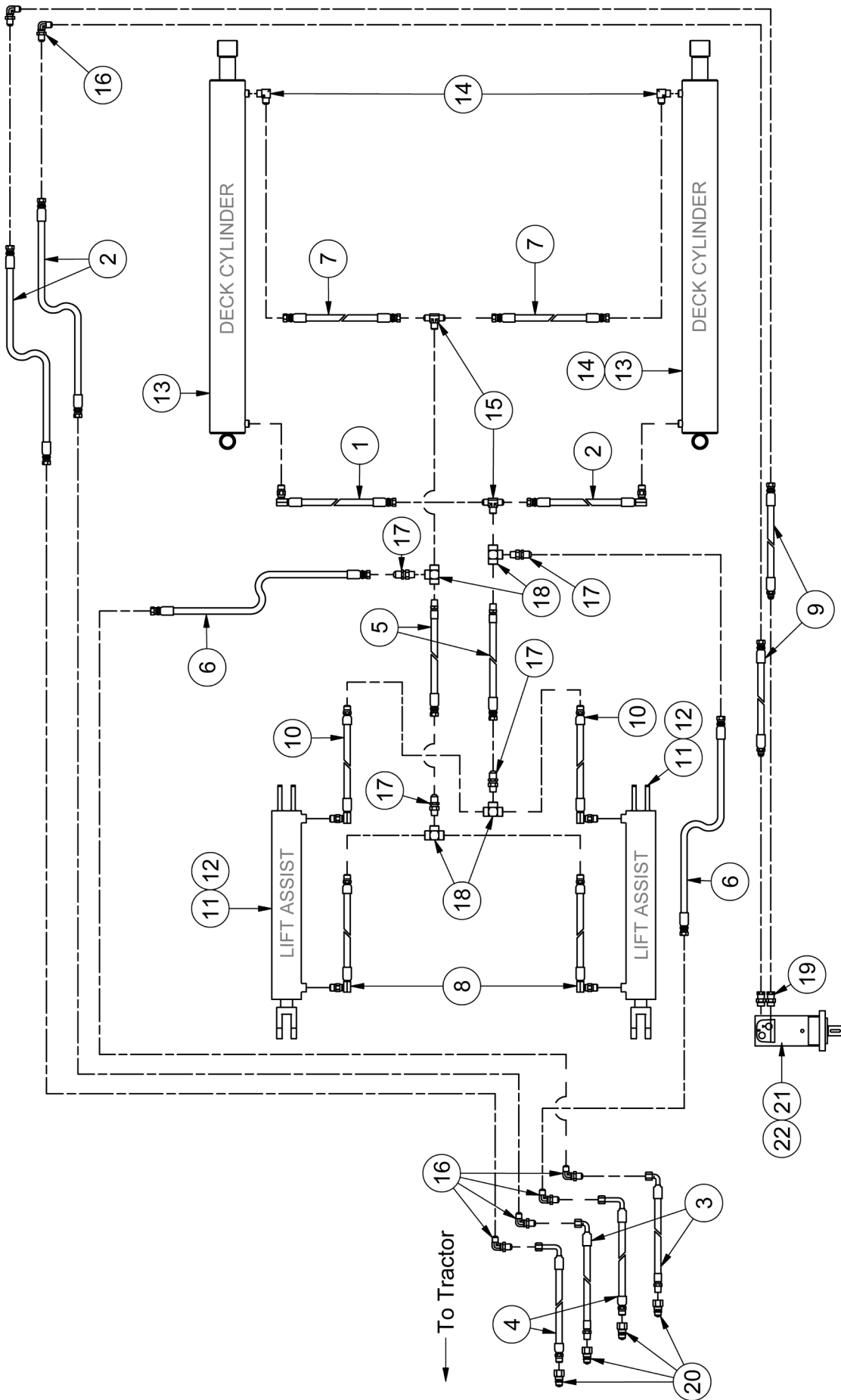

## Hydraulic Layout - Wagon - SN 19B402 to Current

ITEM	QTY	PART NUMBER	DESCRIPTION
1	2	26913	Hose - HH60 - 8AT1(8FJXH,8MBX90) HCL 60"
2	2	28029	Hose - HH192 - 8AT1(8FJXH,8FJXH)HCL 192"
3	4	28234	Hose - HH180 - 8AT1(8MP,8FJXH90S) HCL 180"
4	2	28235	Hose - HH180 - 8AT1(8MP,8FJXH90L) HCL 180"
5	2	28236	Hose - HH18 - 8AT1(8FJXH,8MP) HCL 18"
6	2	28237	Hose - HH139 - 8AT1(8FJXH,8FJXH) HCL 139"
7	2	28238	Hose - HH67 - 8AT1(8FJXH,8FJXH) HCL67
8	2	28240	Hose - HH39 - 8AT1(8MBX90,8MP) HCL 39"
9	2	28241	Hose - HH188 - 8AT1(8MJ,8FJXH) HCL 188"
10	2	30262	Hose - HH37 - 8AT1(8MBX90,8MP) HCL 37"
11	2	BS199899A	Hydraulic Cylinder - 3-1/2" X 20-1/2"
12	2	SK-FH35-20.5	3.5X20.5" Hyd Cyl Seal Kit
13	2	CYL27558	Hydraulic Cylinder - 4" X 40" X 2"
14	2	HF 2501-8-8	Hydraulic Elbow - 1/2" ORB to 1/2" MJIC
15	2	HF 2601-8-8-8	JIC to Pipe Branch Tee
16	6	HF 2701LN-8-8	Hyd. Fitting 1/2" MJIC Bulkhead 90° Long
17	4	HF 2706LN-8-8	Bulkhead Fitting - 1/2" Pipe - 1/2" MJIC
18	4	HF 5605-8	Female Pipe Tee 1/2"
19	2	HF 6402-10-8	Hyd. Fitting #10 Male O-Ring to #8 F JIC
20	8	HF 8010-4	Quickcoupler 1/2" Male Tip
21	2	VAL MLHSY400	Complete Motor - MLHSY400C4UD
22	1	SKMLHSY-U/D	Seal Kit for M+S Motors

# Hydraulic Layout - Shredder - SN 19B402 to Current

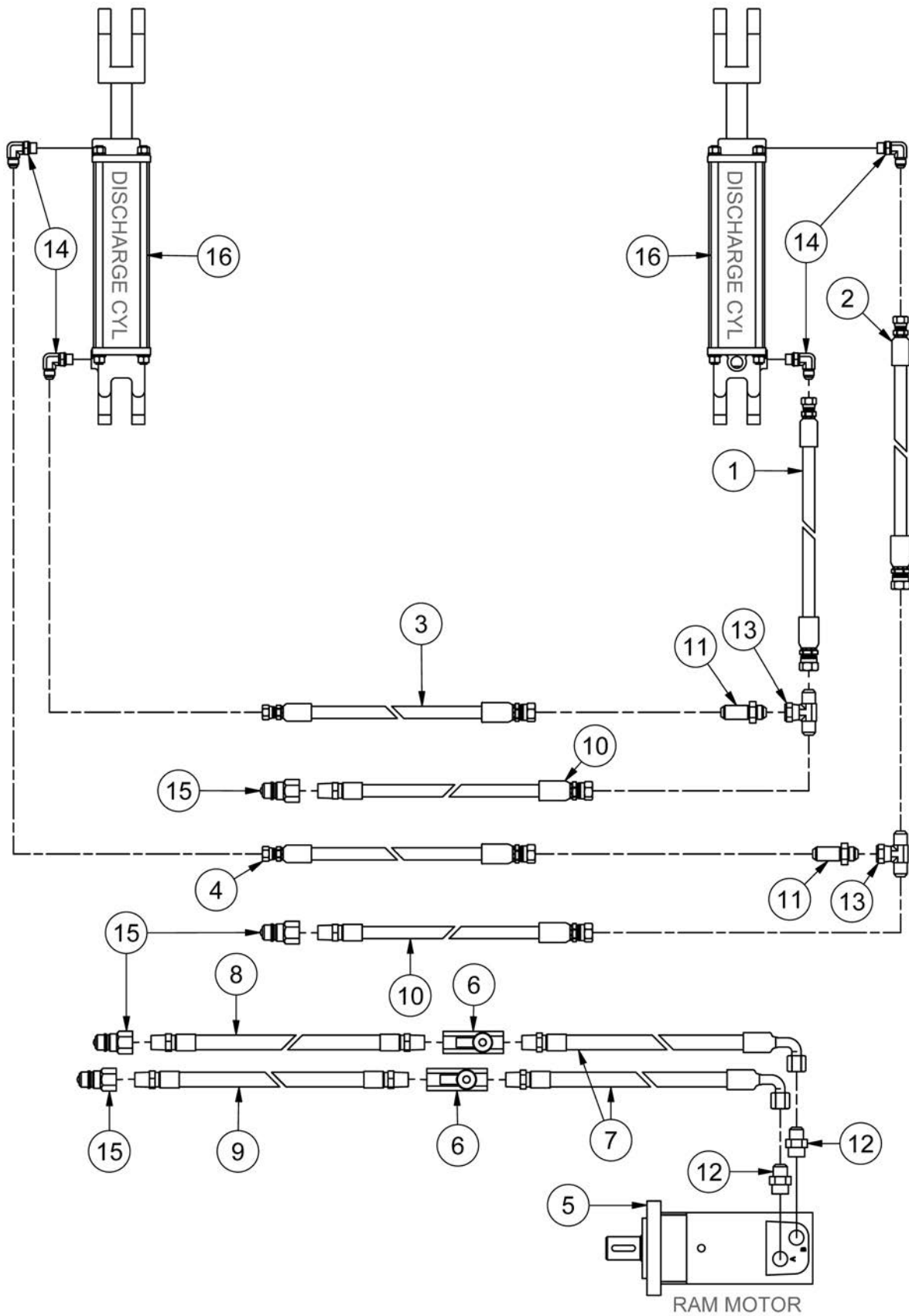

## Hydraulic Layout - Shredder - SN 19B402 to Current

ITEM	QTY	PART NUMBER	DESCRIPTION
1	1	41542	HH43-6AT1(8FJX-6FJX) HCL 43"
2	1	41543	HH53-6AT1(8FJX-6FJX) HCL 53"
3	1	41544	HH91-6AT1(8FJX-6FJX) HCL 91"
4	1	41545	HH104-6AT1(8FJX-6FJX) HCL 104"
5	2	44930	Hydraulic Motor
6	2	44931	Flow Control 1/2NPT
7	2	44932	Hose - HH20 - 8AT1(8MP,8FJXH90) HCL 20"
8	1	44933	Hose - HH136 - 8AT1(8MP,8MP) HCL 136"
9	1	44934	Hose - HH139 - 8AT1(8MP,8MP) HCL 139"
10	2	44935	Hose - HH160 - 6AT1(8MP,8FJXH) HCL 160"
11	2	HF 2700LN-08-08	Hydraulic Fitting - MJIC to MJIC
12	2	HF 6400-8-10	Hyd Fitting - Male JIC - Male ORB
13	2	HF 6600-8-8-8	Hyd. Fitting - Male JIC - Female JIC Tee
14	4	HF 6801-6-6	Hydraulic Fitting - 90 Degree JIC to O-Ring
15	4	HF 8010-4	Quickcoupler 1/2" Male Tip
16	2	TL500-100-082	Hydraulic Cylinder (HYS25SPE08-2176)

# Section 6: Decals

## Decal Locations

NOTE: Decals not to scale.

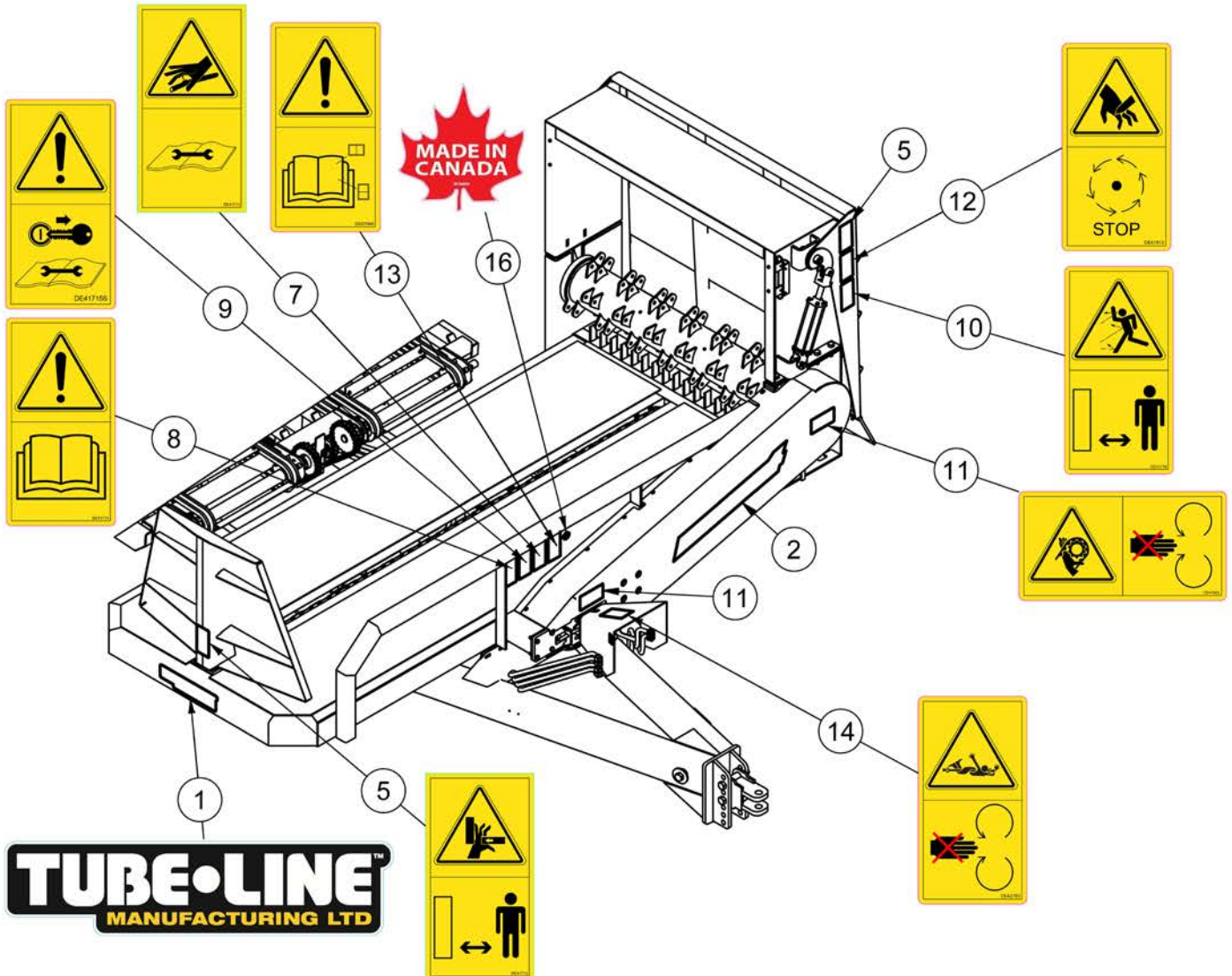
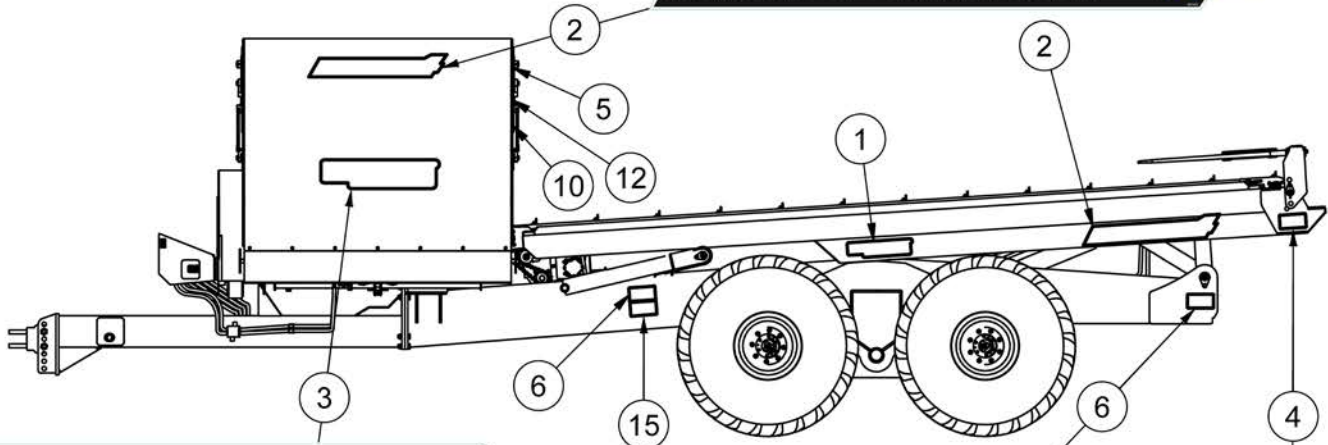

## Decal List

**NOTE:** See Operator's Manual for in depth decal explanations.

<b>ITEM</b>	<b>QTY</b>	<b>PART NUMBER</b>	<b>DESCRIPTION</b>
1	3	DE28146	Tubeline Decal 4" x 16"
2	4	DE30830	Boss IV Model Decal 5.75" x 35"
3	1	DE30837	Tubeline Decal 7.25" x 30"
4	2	DE41711H	ISO Decal - Angled Crush Horizontal
5	3	De41712	ISO Decal - Hand Pinch Point
6	4	DE41712H	ISO Decal - Hand Pinch Point Horizontal
7	1	DE41713	ISO Decal - High Pressure Fluid
8	1	DE41714	ISO Decal - Read Operator's Manual
9	1	DE41715	ISO Decal - Remove Key Before Repair
10	2	DE41718	ISO Decal - Thrown Object Vertical
11	2	DE41902	ISO Decal - Chain Entanglement
12	2	DE41913	ISO Decal - Cutting Hazard
13	1	DE42784	ISO Decal - Read OM Decals Section
14	1	DE42785	ISO Decal - PTO Entanglement
15	2	DE43049	ISO Decal - Wheel Crush
16	1	DECANADA	Decal Made In Canada





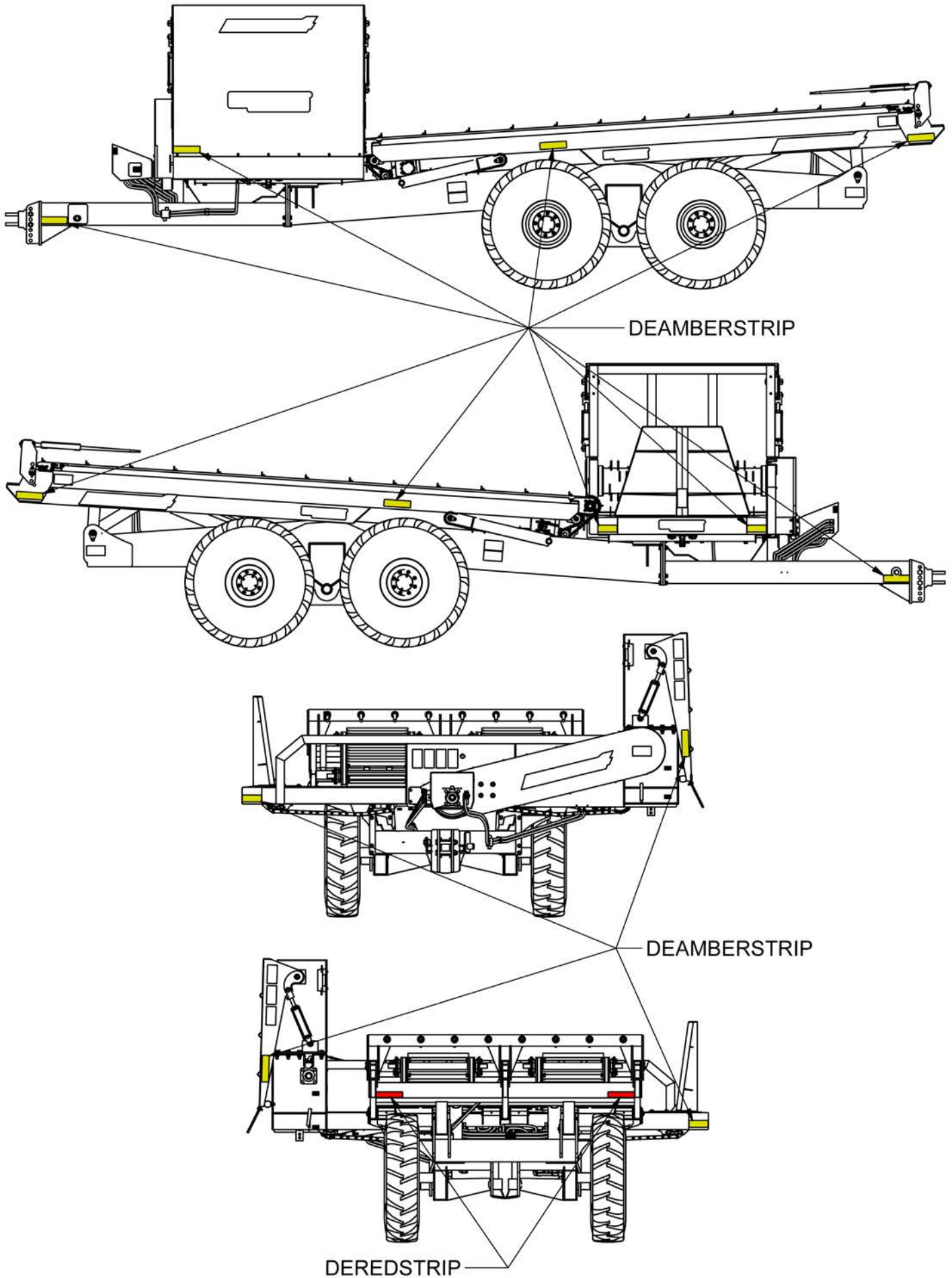





# Clearance Markers

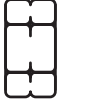

*Intentionally Left Blank*

# Imperial Torque Value Chart

SAE Grade and Head Markings	1 or 2 <sup>b</sup>	5	5.1	5.2	8	8.2
	NO MARK					
SAE Grade and Nut Markings	2	5		8		
	NO MARK					

Size	Grade 1				Grade 2 <sup>b</sup>				Grade 5, 5.1, or 5.2				Grade 8 or 8.2			
	Lubricated <sup>a</sup>		Dry <sup>a</sup>		Lubricated <sup>a</sup>		Dry <sup>a</sup>		Lubricated <sup>a</sup>		Dry <sup>a</sup>		Lubricated <sup>a</sup>		Dry <sup>a</sup>	
	N-m	lb-ft	N-m	lb-ft	N-m	lb-ft	N-m	lb-ft	N-m	lb-ft	N-m	lb-ft	N-m	lb-ft	N-m	lb-ft
1/4	3.7	2.8	4.7	3.5	6	4.5	7.5	5.5	9.5	7	12	9	13.5	10	17	12.5
5/16	7.7	5.5	10	7	12	9	15	11	20	15	25	18	28	21	35	26
3/8	14	10	17	13	22	16	27	20	35	26	44	33	50	36	63	46
7/16	22	16	28	20	35	26	44	32	55	41	70	52	80	58	100	75
1/2	33	25	42	31	53	39	67	50	85	63	110	80	120	90	150	115
9/16	48	36	60	45	75	56	95	70	125	90	155	115	175	130	225	160
5/8	67	50	85	62	105	78	135	100	170	125	215	160	240	175	300	225
3/4	120	87	150	110	190	140	240	175	300	225	375	280	425	310	550	400
7/8	190	140	240	175	190	140	240	175	490	360	625	450	700	500	875	650
1	290	210	360	270	290	210	360	270	725	540	925	675	1050	750	1300	975
1-1/8	400	300	510	375	400	300	510	375	900	675	1150	850	1450	1075	1850	1350
1-1/4	570	425	725	530	570	425	725	530	1300	950	1650	1200	2050	1500	2600	1950
1-3/8	750	550	950	700	750	550	950	700	1700	1250	2150	1550	2700	2000	3400	2550
1-1/2	1000	725	1250	925	990	725	1250	930	2250	1650	2850	2100	3600	2650	4550	3350

DO NOT use these values if a different torque value or tightening procedure is given for a specific application. Torque values listed are for general use only. Check tightness of fasteners periodically.

Shear bolts are designed to fail under predetermined loads. Always replace shear bolts with identical grade.

Fasteners should be replaced with the same or higher grade. If higher grade fasteners are used, these should only be tightened to the strength of the original.

Make sure fasteners threads are clean and that you properly start thread engagement. This will prevent them from failing when tightening.

Tighten plastic insert or crimped steel-type lock nuts to approximately 50 percent of the dry torque shown in the chart, applied to the nut, not to the bolt head. Tighten toothed or serrated-type lock nuts to the full torque value.

<sup>a</sup> "Lubricated" means coated with a lubricant such as engine oil, or fasteners with phosphate and oil coatings. "Dry" means plain or zinc plated without any lubrication.

<sup>b</sup> Grade 2 applies for hex cap screws (not hex bolts) up to 152 mm (6-in.) long. Grade 1 applies for hex cap screws over 152 mm (6-in.) long, and for all other types of bolts and screws of any length.

# Metric Torque Value Chart

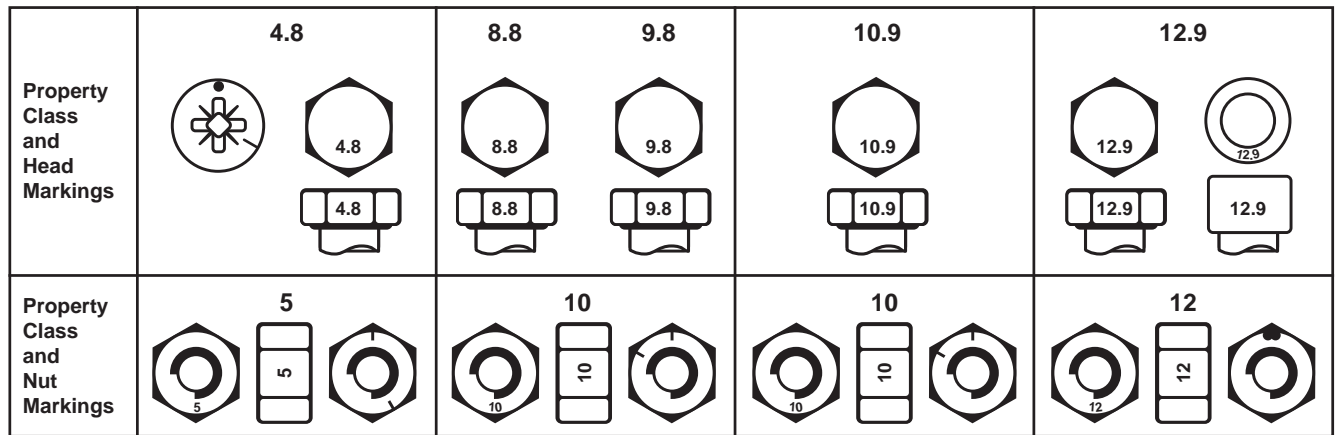

Size	Class 4.8				Class 8.8 or 9.8				Class 10.9				Class 12.9			
	Lubricated <sup>a</sup>		Dry <sup>a</sup>		Lubricated <sup>a</sup>		Dry <sup>a</sup>		Lubricated <sup>a</sup>		Dry <sup>a</sup>		Lubricated <sup>a</sup>		Dry <sup>a</sup>	
	N-m	lb-ft	N-m	lb-ft	N-m	lb-ft	N-m	lb-ft	N-m	lb-ft	N-m	lb-ft	N-m	lb-ft	N-m	lb-ft
M6	4.8	3.5	6	4.5	9	6.5	11	8.5	13	9.5	17	12	15	11.5	19	14.5
M8	12	8.5	15	11	22	16	28	20	32	24	40	30	37	28	47	35
M10	23	17	29	21	43	32	55	40	63	47	80	60	75	55	95	70
M12	40	29	50	37	75	55	95	70	110	80	140	105	130	95	165	120
M14	63	47	80	60	120	88	150	110	175	130	225	165	205	150	260	190
M16	100	73	125	92	190	140	240	175	275	200	350	255	320	240	400	300
M18	135	100	175	125	260	195	330	250	375	275	475	350	440	325	560	410
M20	190	140	240	180	375	275	475	350	530	400	675	500	625	460	800	580
M22	260	190	330	250	510	375	650	475	725	540	925	675	850	625	1075	800
M24	330	250	425	310	650	475	825	600	925	675	1150	850	1075	800	1350	1000
M27	490	360	625	450	950	700	1200	875	1350	1000	1700	1250	1600	1150	2000	1500
M30	675	490	850	625	1300	950	1650	1200	1850	1350	2300	1700	2150	1600	2700	2000
M33	900	675	1150	850	1750	1300	2200	1650	2500	1850	3150	2350	2900	2150	3700	2750
M36	1150	850	1450	1075	2250	1650	2850	2100	3200	2350	4050	3000	3750	2750	4750	3500

DO NOT use these values if a different torque value or tightening procedure is given for a specific application. Torque values listed are for general use only. Check tightness of fasteners periodically.

Shear bolts are designed to fail under predetermined loads. Always replace shear bolts with identical property class.

Fasteners should be replaced with the same or higher property class. If higher property class fasteners are used, these should only be tightened to the strength of the original.

Make sure fasteners threads are clean and that you properly start thread engagement. This will prevent them from failing when tightening.

Tighten plastic insert or crimped steel-type lock nuts to approximately 50 percent of the dry torque shown in the chart, applied to the nut, not to the bolt head. Tighten toothed or serrated-type lock nuts to the full torque value.

<sup>a</sup> "Lubricated" means coated with a lubricant such as engine oil, or fasteners with phosphate and oil coatings. "Dry" means plain or zinc plated without any lubrication.

# Index

Clearance Markers . . . . .	.6-3
Decal List . . . . .	.6-2
Decal Locations . . . . .	.6-1
Deck Drive . . . . .	.4-8
Deck Frame . . . . .	.4-6
Hydraulic Layout - Shredder - SN 19B402 to Current. . . . .	.5-5
Hydraulic Layout - Up to SN 19B401. . . . .	.5-1
Hydraulic Layout - Wagon - SN 19B402 to Current . . . . .	.5-3
Imperial Torque Value Chart . . . . .	.7-1
Learn Machine Safety . . . . .	.1-1
Lift Assist . . . . .	4-10
Main Frame & Axles . . . . .	.4-2
Maintenance Safety . . . . .	.1-2
Manuals . . . . .	. I
Metric Torque Value Chart . . . . .	.8-1
Operating Procedure. . . . .	.3-1
Operational Safety . . . . .	.1-1
Operator's Manual . . . . .	. I
Parking Safety. . . . .	.1-2
Part Orders . . . . .	. I
Parts Section Usage. . . . .	. I
Pre-Operation . . . . .	.1-1
Pre-Operation . . . . .	.3-1
Safety Signal Words / Safety Messages. . . . .	.1-1
Section 1: Safety . . . . .	.1-1
Section 2: Adjustments & Maintenance . . . . .	.2-1
Section 3: Operation . . . . .	.3-1
Section 4: Basic Parts . . . . .	.4-1
Section 5: Hydraulics . . . . .	.5-1
Section 6: Decals. . . . .	.6-1
Serial Number. . . . .	. I
Shredder Chain Drive - SN 19B402 to Current. . . . .	4-18
Shredder Chain Drive - Up to SN 19B401 . . . . .	4-16
Shredder Flail Drum - SN 19B402 to Current . . . . .	4-22
Shredder Flail Drum - Up to SN 19B401. . . . .	4-20
Shredder - SN 19B402 to Current. . . . .	4-14
Shredder - Up to SN 19B401 . . . . .	4-12
Tongue - SN 19B402 to Current . . . . .	.4-5
Tongue - Up to SN 19B401. . . . .	.4-4
Transport Safely . . . . .	.1-1
Warranty and Limitation of Liability . . . . .	. II



Scan with smartphone to  
download latest manual.

**CALIFORNIA**

**Proposition 65 Warning**

Battery posts, terminals, and similar parts may contain lead which are known to the State of California to cause cancer and reproductive harm.  
Wear gloves and wash hands after handling.

**TUBE•LINE™**